

PRODUCT

# HiPER Ring vs. RSTP

ANALYSIS

## Redundancy Process with Hirschmann Switches

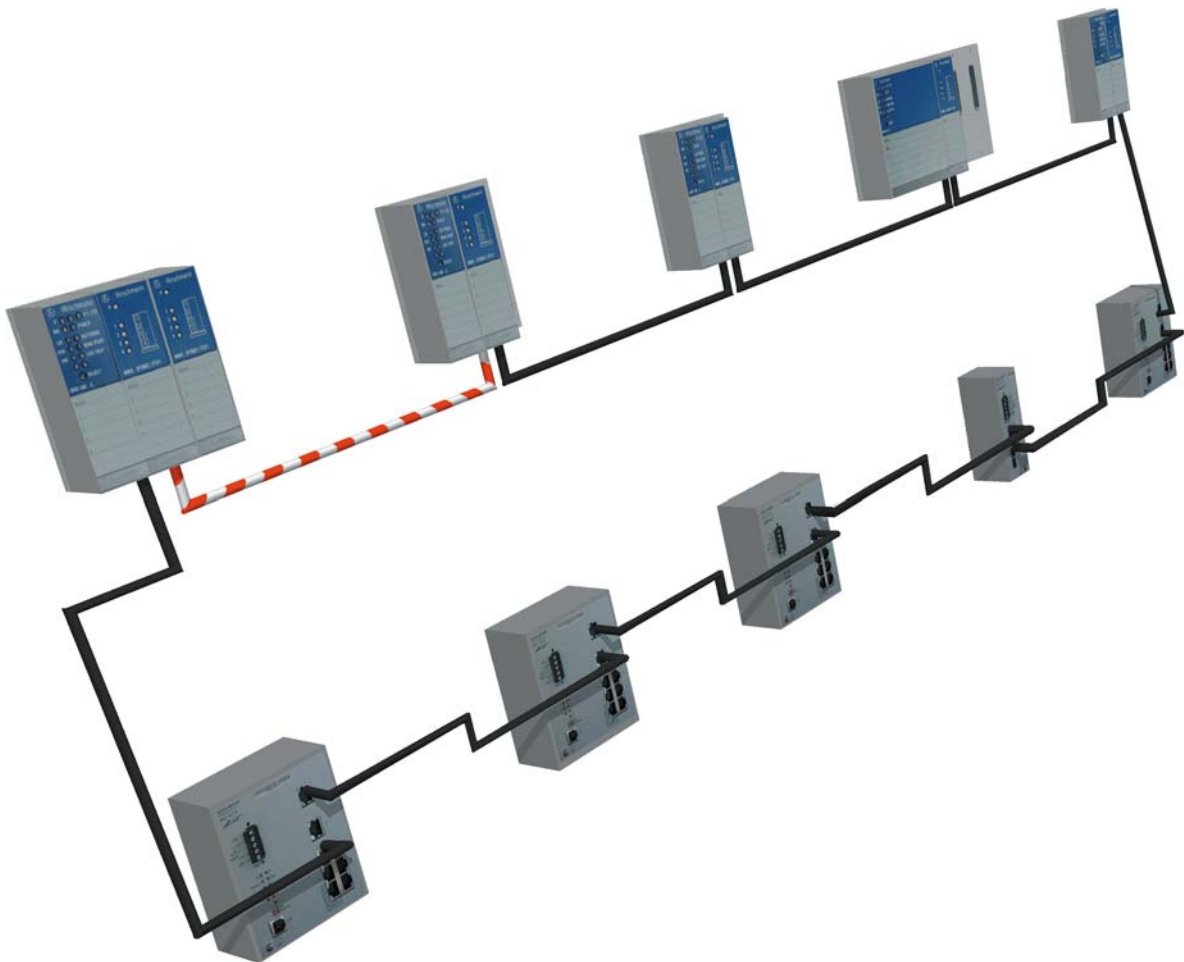

# **Product Analysis: HiPER Ring vs. RSTP**

## **Redundancy Process with Hirschmann Switches**

**Markus Schaub**  
**Hartmut Kell**

All rights reserved. No part of this report may be reproduced or transmitted in any form or by any means, electronic or mechanical, including photocopying, recording, or by any information storage and retrieval system, without written permission from the publisher, except for the inclusion of brief quotations in a review.

Marketing and translation into other languages are subject to prior written permission by ComConsult Technologie Information GmbH

The authors and the publisher have made every effort to make this document error-free and as accurate as possible. No warranty or fitness is implied.

The information is provided on an “as is” basis. The authors and the publisher shall have neither liability nor responsibility to any person or entity with respect to any loss or damage arising from the information contained in this book.

Reproduction of the product names, brand names, trademarks, service marks, trade descriptions, etc., even without special marking, should not be regarded as affecting the validity of such names or marks. The authors and the publisher adapt their way of writing in major part to that of the producer, but cannot attest to the accuracy of this information.

ComConsult Research represents the product and technology test laboratory of ComConsult Technologie Information GmbH.

Copyright of the English edition: © 2003 by ComConsult Technologie Information GmbH.

First edition dated 11th November, 2003

Feel free to send your comments and questions to:

ComConsult Technologie Information GmbH  
Pascalstraße 25 52076 Aachen

+49 (2408) 955 400 +49 (2408) 955 399

E-Mail: [Hoechel@comconsult-research.com](mailto:Hoechel@comconsult-research.com)

## **Index**

<b>MOTIVATION AND SUMMARY</b>	<b>1</b>
<hr/>	
<b>HIRSCHMANN PRODUCTS IN THE TEST</b>	<b>3</b>
<hr/>	
RAIL-Switches	3
MICE-Switches	3
MACH 3000 Switches	4
<b>INDUSTRIAL SUITABILITY</b>	<b>5</b>
<hr/>	
<b>INSTALLATION AND MANAGEMENT</b>	<b>9</b>
<hr/>	
Menu-driven User Interface	9
WEB Interface	9
Network Management Tool HiVision	10
Unit Exchange with the Auto-Configuration Adapter (ACA)	12
Modularity: Addition/Exchange in Operation	12
Help Functions	13
Summary	13
<b>REDUNDANCY PROCESS</b>	<b>14</b>
<hr/>	
RSTP	14
Hirschmann Process	14
<b>TEST OF THE REDUNDANCY PROCESSES</b>	<b>19</b>
<hr/>	
Test Processes Applied	19
HiPER-Ring	19
Ring coupling	24
Dual Homing	25
HiRRP	26
HiPER Ring vs. RSTP	27
<b>SUMMARY AND DISCUSSION OF THE RESULTS</b>	<b>31</b>
<hr/>	

## Motivation and Summary

For more than 10 years, Ethernet has been established in master computer systems both in production and industry environments. Nowadays the availability of modern switch systems for direct production environments more and more often tends to generate projects where the traditional bus systems installed underneath the master level, such as the profi bus, are replaced by Ethernet as well.

This product test is designed to analyse whether Ethernet switch systems are in fact suitable for this application case. As test products the Ethernet switch products of Messrs. Hirschmann Electronics GmbH & Co. KG are used. For more than 15 years, the network products produced by Hirschmann have successfully been in use in this domain. Still, the question remains to be answered whether these products enable an application directly involved in data processing of this kind.

The test is focussed on the following major issues:

1. Suitability for industrial surroundings
2. Easy handling.
3. Reaction in cases of failure in the network.

The third item is of special significance here since Hirschmann applies a priority method by installing the HiPER Ring. The HiPER Ring is not only limited to Hirschmann components but presents (almost) industrial standard which is also applied by Siemens, Schneider Electric and Phoenix Contact. The reason for this divergence from the usual standardized Rapid Reconfiguration Spanning Tree is its better suitability regarding technical and production requirements. Exactly here will our test set in by drawing a comparison between the performances of the HiPER Ring and the RSTP method when located within the typical scenario.

Our test will arrive at the following results:

1. The requirements to be met by network products in industrial environments may significantly vary from the conditions of office environments. Even if in practice only part of the production is faced with tough environmental conditions the prerequisite of uniform installations prescribes the use of products which are capable of fulfilling such requirements. The Hirschmann products tested here have been designed for this special application and they outdo the performances of comparable products used in office environments by far.
2. Both the web operation surfaces of the tested products and the Management Tool HiVision have been structured clearly and they have been provided with very good documentation. Even someone not working with it every day will be familiar with it very soon and the help function will offer extensive explanations on the configuration parameters.
3. Under certain conditions, the HiPER-Ring method is by far superior to the standardized RSTP method. Here the implementation used in the test in comparison with the RSTP method by CISCO must be regarded as a very good implementation. In the lab, other implementations were tested which gave considerably worse results. The Hirschmann process has always got an advantage when a chain of systems has to be switched to it in a row or in a circle. The failover time is independent of the number of switches used, while, with the RSTP method, down time and number of switches are closely interrelated.

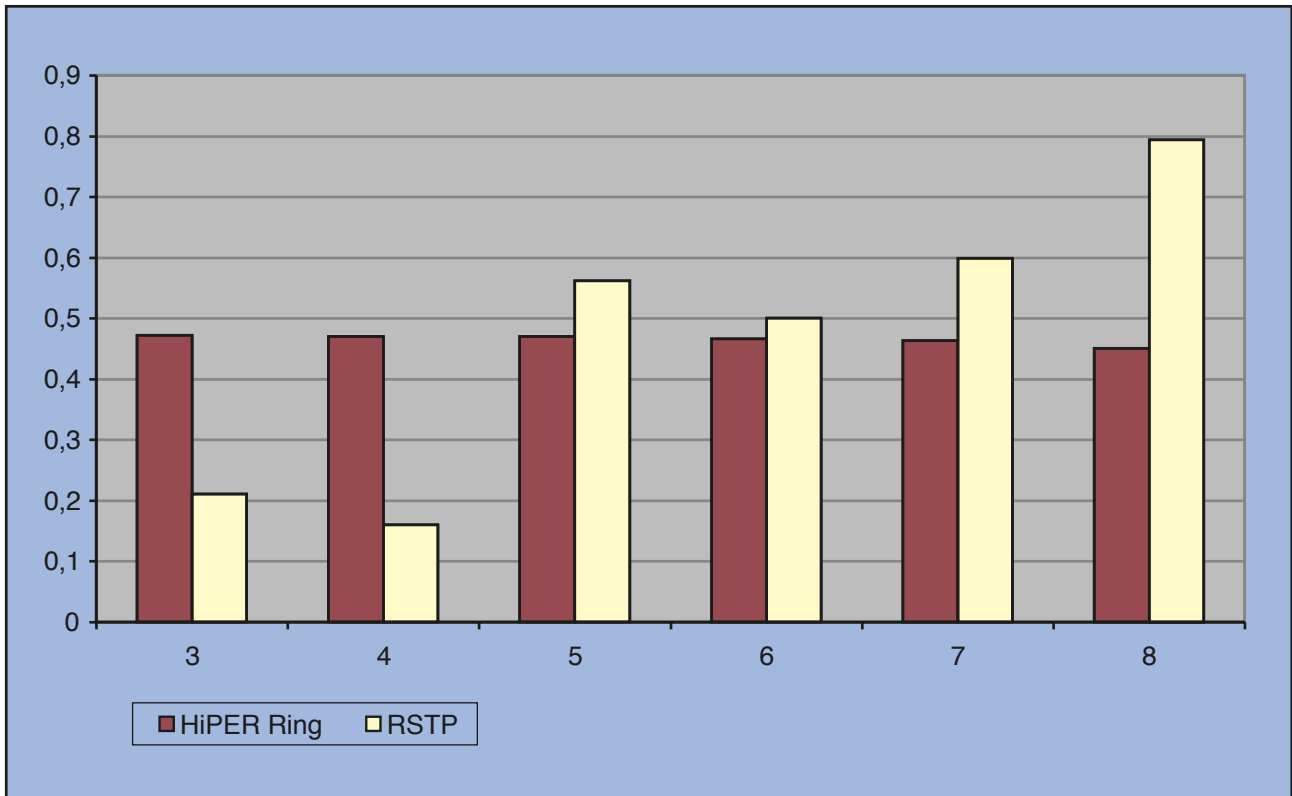

Picture 1: Increase of the failover time in relation with number of switches

**Conclusion:**

In many cases, network products which are designed for office environments will not meet the requirements set by industrial environments. The Hirschmann products tested in this test reveal the differences between industry and office products. They fulfil the highly demanding requirements of data processing in production environments.

## Hirschmann Products in the Test

### RAIL-Switches



**Picture 2: RAIL Switch**

The case of the RAIL switch series consists of compact and firmly installed devices for industrial application. There is a great number of different systems, regarding both the number as well as the type of ports available.

The switches are supplied with 24 V DC and, for redundancy purposes, can be configured with two independent power supplies. The RAIL switches support both the HiPER Ring (for this purpose two ports have been foreseen) and the redundant ring interconnection. For the latter, a fixed standby port has also been pre-configured which cannot be used for the data packets either.

The functions Ring Manager and Standby Manager are configured by DIP switches on the front face of the unit.

### MICE-Switches



**Picture 3: MICE Switches**

The latest generation of Hirschmann industrial switches is the MICE series. In contrast to the RAIL systems, these switches have a modular structure. They consist of a back-plane which, alike the RAIL switches, is mounted on top hat rails, a basic unit and several slots for modules. All modules can be combined with all backplane variants, even if the construction height of the modules and the basic unit is varying.

Alike the RAIL systems, the MICE switches are also supplied with 24 V DC and can be connected redundantly. In contrast to the RAIL series, however, the network connections are located at the bottom side of the unit.

As redundancy functions, the HiPER-Ring and the redundant ring interconnection are available.

## MACH 3000 Switches



**Picture 4: MACH 3002**

The switches of the MACH series consist of a chassis with a passive backplane and one or more basic boards. Each basic board is built with a modular structure and thus is an independent switch so that a central switch module can be dropped. This will enhance failure security significantly since one unit will still be able to function even if individual modules stop working.

The power can either be supplied via power packs with 220 V or via 24 V. It goes without saying that the power supply of the MACH unit is also designed on the principle of redundancy.

By way of one or several router modules it is possible to change a MACH switch into a Layer-3 switch. The Layer-3 techniques thus made available are static routing entries and HiRRP is the router redundancy solution.

On Layer 2, the MACH switches support the HiPER Ring for Fast and Gigabit-Ethernet as well as Dual Homing.

By the end of 2003, RSTP will also be supported by MACH, MICE and RS2 so as to offer compatibility to other manufacturers.



## Industrial Suitability

Industrial environments differ largely from office environments. In particular, in the case of special environment conditions the application of switch products, as have been used in local networks for years, is doubtful here. However, this question cannot be answered in general since, firstly, the environment conditions are varying considerably from case to case and, secondly, a difference must be made between environment condition and installation situation. In each case, a project-specific individual decision will be taken which will depend on the requirements of the respective underlying situation.

Some manufacturers offer switch systems which are specially designed for the industrial area. Here the definition of suitability is not up to the manufacturer but is stipulated clearly by various standardization guidelines. Accordingly, the buyer of industrial switch systems should take these standards as a basis of decision. Since most of the properties stipulated in these standards cannot be verified by the end customer himself the manufacturers are also called upon to prove adherence to the respective standard criteria in a verifiable way.

In general, when talking about the industrial suitability of switches the following requirements are drawn up to fulfil these suitability criteria:

- Protection against water, liquids and dust
- Enhanced thermic resistance
- Enhanced mechanic resistance
- Enhanced EMV stability
- DC voltage supply
- Data connections suitable in the industry

The requirement regarding enhanced „tightness” against liquids and dust is seldom, however, on the other side, with a view to market and product situation a k.o.-criterion. Standard IP67 provides for the highest protection class for a completely closed unit casing which means highest requirements regarding both the construction of the case itself and the thermic resistance. However, in most application cases, a switch can relatively easily be mounted in a completely dense casing. The market situation vis-a-vis such requirements does not leave any questions here. More than 99% of all switch systems offered are IP20 and they are designed for office environments. Hirschmann is among the few manufacturers able to offer an IP67 switch.

However, mounting a switch in a closed cabinet housing will rise another, in fact very significant problem: The heat produced by the switch can only with difficulty escape from a dense housing which will cause a rise in temperature in the cabinet and in the switch itself. When do we talk of enhanced thermic load? Here some typical operation temperature ranges:

- "office suitable" switch systems can be operated at temperatures ranging between  $-5^{\circ}\text{C}$  and  $+45^{\circ}\text{C}$ .
- The IAONA cabling guideline defines the range between  $0^{\circ}\text{C}$  and  $+55^{\circ}\text{C}$ .
- Twisted-pair installation cables can be operated at temperatures between  $-20^{\circ}\text{C}$  and  $+60^{\circ}\text{C}$ .
- Light wave conductor cables can be operated at temperatures between  $-5^{\circ}\text{C}$  and  $+70^{\circ}\text{C}$ .

First Index	Contact Protection	Foreign Bodies Protection	Second Index	Water Protection
0	No particular protection		0	No particular protection
1	Against large body surfaces	Big foreign bodies diameter > 50 mm	1	Against vertically falling dripping water
2	Against fingers or objects of similar size	Medium-sized foreign bodies diameter > 12 mm	2	Against diagonally falling dripping water (up to 15° deviation from the perpendicular line)
3	Against tools, wires and similar objects of a thickness > 2,5 mm	Small foreign bodies diameter > 2,5 mm	3	Against water spray (any direction with up to 60° deviation from the perpendicular line)
4	Complete protection	Grain-shaped foreign bodies diameter > 1 mm	4	Against water spray from all directions
5	Complete protection	Dust-protected, dust deposits are tolerable but their quantity must not impede the function of the unit	5	Against water jets from a nozzle from all directions
6	Complete protection	Complete dust-protected	6	Against flooding
			7	Against submersion
			8	Against total immersion

**Table 1: Definition of IP-Protection Class**

All industry suitable systems of Hirschmann tolerate an ambient operation temperature of 0° C to +60° C which is significantly higher than the switches “only” suitable for office environment. If a switch would be applied in an environment with higher temperatures one would note that standard installation cables are no longer applicable in this environment either. But Hirschmann also supplies EEC (Extended Environmental Conditions) types with extended temperature ranges of -40°C to +70°C.

The majority of Ethernet switches or hubs installed today in hall operation mode is

located outside machine cabinets in field level. Here cranes, fork lifts or even the personnel would rather present a “mechanical” danger for the components. This particularly applies to wall cabinets and standing cabinets which are often installed in unfavourable positions. In a closed distribution cabinets or in a machine mounted in field level one has to take into account both massive mechanical damage and strong and high-frequency vibrations. Especially affected by such damage are plug connections, adapter cards and optionally mounted switches or hubs/converters.

When specifying active components many manufacturers of industrial switches refer, for instance, to the following two standards (Unit “g” is a measure for the gravity):

- EN 60068-2-6 A (requirement to vibration resistance with 5 g at 10 to 150 Hz)
- EN 60068-2-27 (requirement to shock resistance at 15 g to 11 ms)

If you compare the market and, in particular, the Hirschmann products with these specifications you will find that this requirement is also “met” by Hirschmann. If, for instance, in the machine environment, higher loads arise their value must be known precisely, and tests in cooperation with the manufacturers of the components are indispensable.

The difference of the requirements considered to date are loads produced in the environment by electro-magnetic disturbances (EMI). They must be expected at any place within the industrial surrounding, not just in the vicinity of the machine, and there are also heavy disturbances which are difficult to calculate. For most of the users/palners of an industrial environment, it is difficult to estimate what EMI disturbances precisely have to be expected and what way they will take. The requirement that compoments should offer a high EMC resistance especially refers to minimum disturbance resistance and maximum disturbance emission. Disturbance compatibility and disturbance sensibility of a communication system are described by two “core standards“:

- Disturbance emission according to EN 55022
- Disturbance resistance according to EN 55024

EN 55022 defines the application ranges Industry (radiation class A) and Living/Office (radiation class B). When planning and, in particular, when deciding on a cabling system, however, it is in most cases recommendable to adhere to the more “severe” radiation class B. In analogy to EN 55022, there is also a similar subdivision for EN 55024 which, in most cases, demands adherence to the more severe part 2. There is quite often some confusion when reference is made to the former standards EN 50081 and 50082. These are standards which stipulate a specification on EMC resistance for all electric components in the living or industrial environment. The above cited standards EN 550xy were developed from these two standards. However, in the domain of the disturbance resistance a weakening of the requirements was observed.

When choosing active components one has to distinguish between those which must be mounted “EMC unprotected” and those to be installed inside an additional EMC-resistant cabinet. In the first case, an adherence to the above described standards is demanded as obligatory and to be confirmed by the manufacturers. In the product documentation, Hirschmann confirms adherence to both standards.

Particularly in the immediate vicinity of the machine installation there is no 230 V alternating voltage available but 24 V direct voltage so that, in principle, space-consuming power packs could be dispensed with. This infrastructure is also used by industrial switches and it is nowadays general practice and standard that switches for industrial applications do no longer have a power pack but a terminal block for connection to such direct power sources.

If such voltage supply is missing at the place of installation the switch manufacturers offer top hat rail mountable power packs with different power per-formances. Hirschmann equip their systems with connections for 24 Volt direct current and offers compatible network parts which can also supply a switch redundantly.

The possibility of using a data connection inside an industrial surrounding considerably depends on two prerequisites which have already been described above:

- Will a switch remain dense with the data plug connected?
- What is the reaction of the connections like when exposed to heavy mechanical impacts?

Since, as already mentioned above, switches hardly offer a higher IP protection class than IP20 there is little sense in demanding an especially “dense” plug connection for such types. As a consequence, the few IP67 switches are exclusively manufactured with special data connections. For instance, in the case of the Hirschmann IP67 switch this is a M12 plug.

When considering the mechanical requirements one would rather expect that, in case of vibrations or even falls, the internal switch hardware such as mother board, internal plugs, skirting board for RAM and the like would rather be affected instead of a RJ45 plug which, once plugged-in and firmly seated, will not be dislodged by such loads and impacts.

In the end, an analysis regarding the question what plug should be used will lead to the re-sult that the extremely high number of indi-vidual cases will try to cope with the plug technology traditionally used in office sur-roundings such as RJ45, ST or SC . If, in special cases, particularly high requirements should require “better” plugs, in view of today’s state of standardization proprietary solutions will be indispensable. Hirschmann is one of the very few manufacturers who are able to offer IP67-suitable connection techniques with improved mechanical properties for a certain type (FE-IP67-4TX with four Fast-Ethernet suitable copper connections).

In the near future, Hirschmann will launch another IP67-switch on the market, i. e. the OCTOPUS 5TX with five Fast-Ethernet suitable standard-compatible M12 connections.

## Installation and Management

### Menu-driven User Interface

The putting into operation of all tested Hirschmann components was at first effected in the same way. By means of a special cable the serial COM-Port of the computer

is connected with a V.24 of the respective switch. Subsequently, it is possible to set up a first connection by means of a hyper-terminal programme.

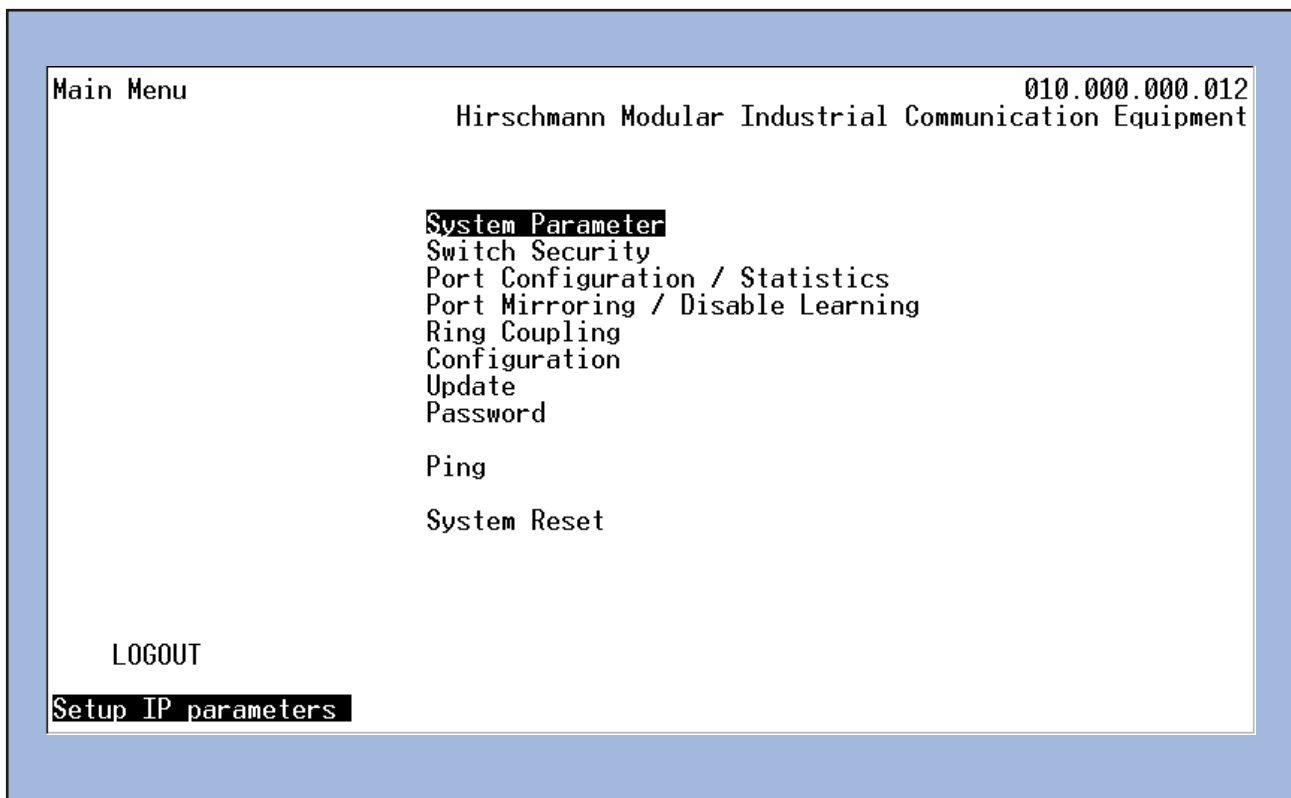

**Picture 5: Configuration via hyper-terminal**

The user interface is completely menu-driven, and, unlike products of many other manufacturers, there is no command line interface. It is primarily designed for the first configuration since not all functionalities can be configured from here.

### WEB Interface

Each of the systems tested is equipped with an integrated http server by means of which configuration of the switches via Browser can easily be effected. Precondition for an access to the Browser is that an extra Java

environment of SUN has been installed on the respective computer in addition to the Browser which can be downloaded from the SUN-Homepage or copied from the CD delivered free of charge with the product. In contrast to the user interface, with the WEB interface it is possible to completely configure all functionalities of the systems.

After call-up of the IP addresses of the switch a Java applet is transferred from the switch to the PC. If you dispose of many systems of the same type and with the same software version it is reasonable to pre-install the applet on a management station as well so as to save downloading time.

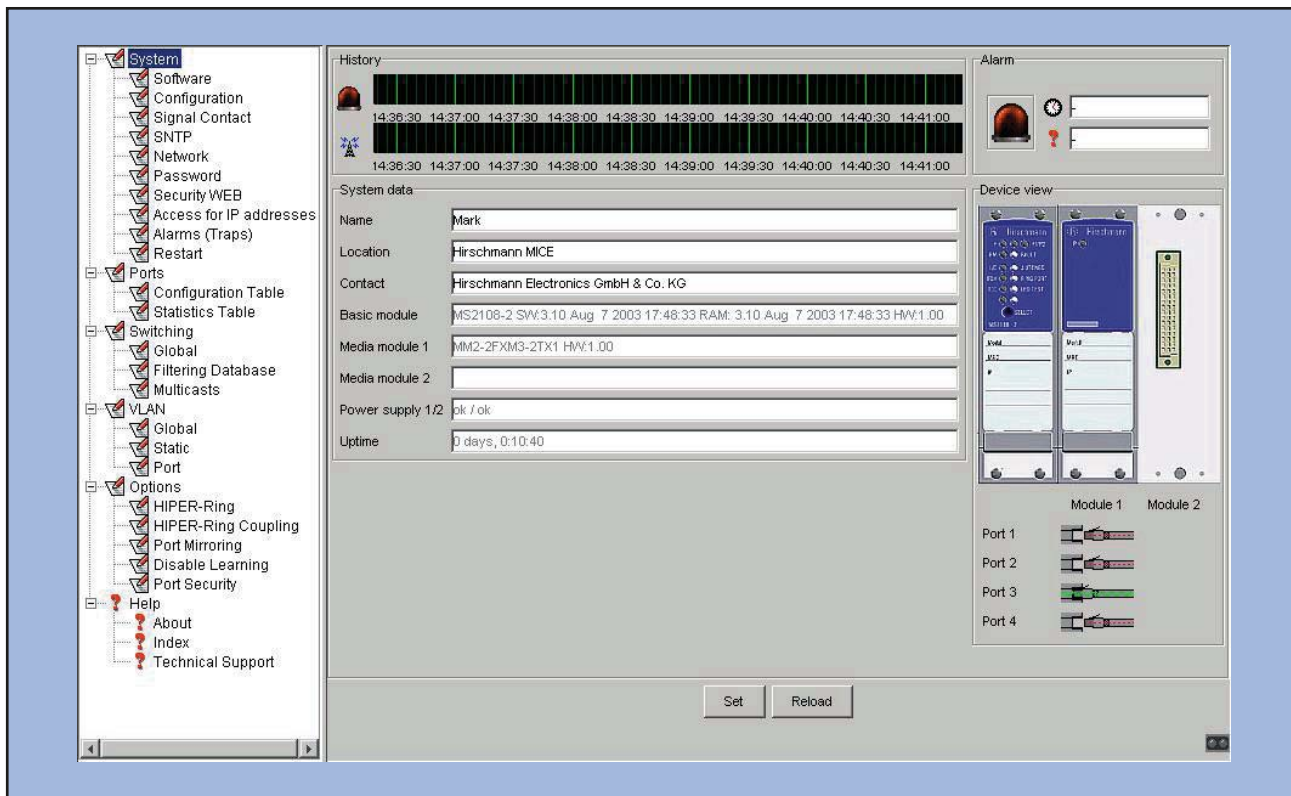

**Picture 6: Access via WEB Interface**

An argument in favour of this process is the speed of the applets which can be characterized as extremely fast compared to similar applications of many other manufacturers. Besides the surface has been designed very clear and user-friendly and there are numerous and detailed help functions. The surface and the help menu can be loaded either in German or English. Apart from a separate help function at the bottom of the selection menu (see Picture 6), most of the functions are also documented directly and in a very detailed way in the window where the adjustments are made. From the help function it is again possible to jump to the configuration of the respective features.

Apart from pure configuration, the different available stati of a system can be inquired and indicated, such as voltage supply, interface stati and counter, port stati of the HiPER

Ring ports. Serious errors are already indicated, right after login, on the entry page in the "Alarm" field. In the example shown here, the alarm is marked in red and a failure of one of the two voltage supply sources is signaled. What alarms are reported and in what colour (green, yellow or red) can be configured individually.

Besides, it should be noted that, apart from some basic adjustments, the configuration changes at Hirschmann will become active immediately but, after a new start, will remain valid only if explicitly stored.

**Network Management Tool HiVision**

Picture 7 shows the survey page of the programme. At first sight you can see which systems are included in the system. Besides you get further important information on the



stations managed. Thus you can recognized errors immediately by the red "Smilies" and search for the reasons.

In addition to the survey, this entry mask offers the possibility of managing VLANs and events

reported by the switches are gathered and listed in a table.

On the basis of this mask you can configure the switches individually but a configuration of several systems at a time is possible, too.

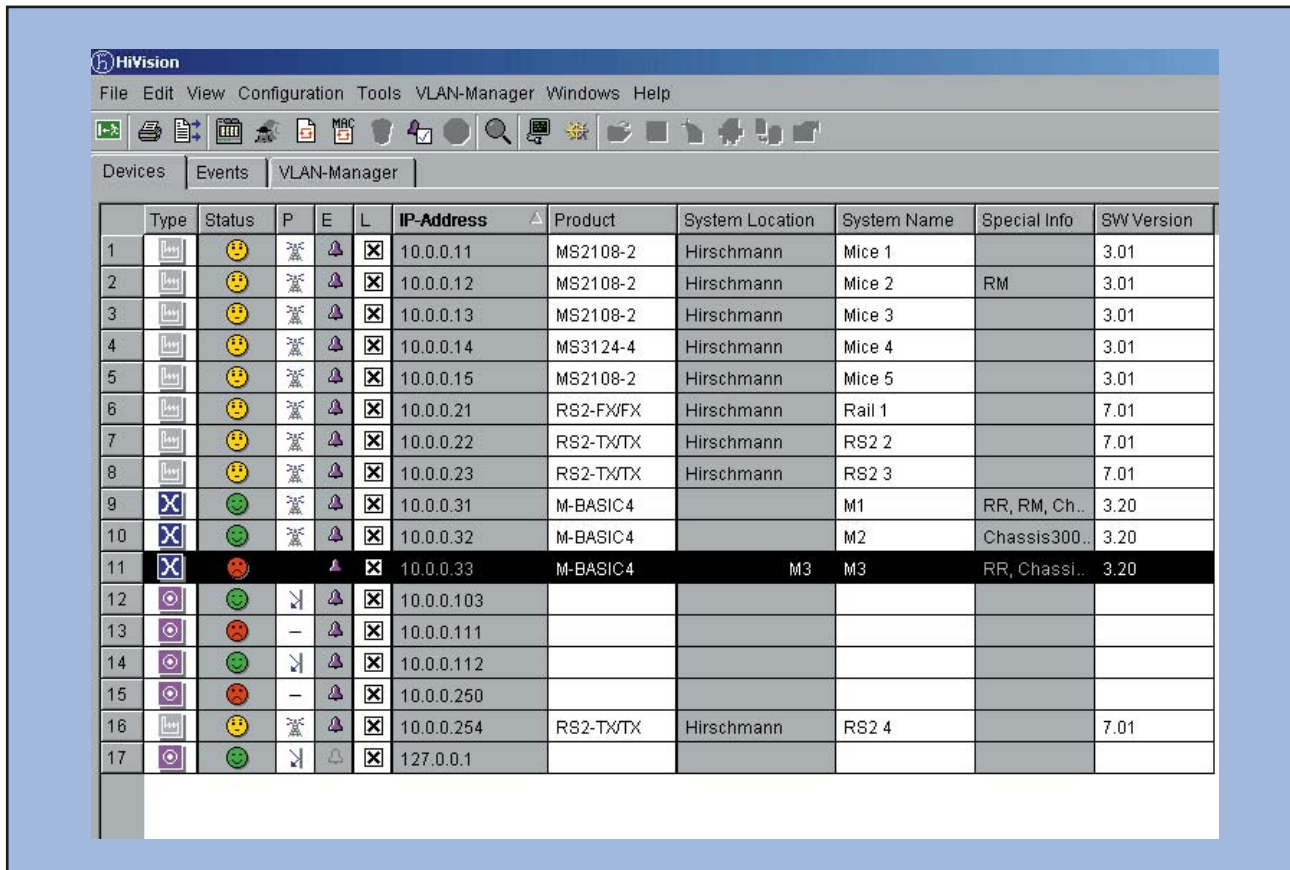

	Type	Status	P	E	L	IP-Address	Product	System Location	System Name	Special Info	SW Version
1	[Icon]	☹️	🔒	🔔	☒	10.0.0.11	MS2108-2	Hirschmann	Mice 1		3.01
2	[Icon]	☹️	🔒	🔔	☒	10.0.0.12	MS2108-2	Hirschmann	Mice 2	RM	3.01
3	[Icon]	☹️	🔒	🔔	☒	10.0.0.13	MS2108-2	Hirschmann	Mice 3		3.01
4	[Icon]	☹️	🔒	🔔	☒	10.0.0.14	MS3124-4	Hirschmann	Mice 4		3.01
5	[Icon]	☹️	🔒	🔔	☒	10.0.0.15	MS2108-2	Hirschmann	Mice 5		3.01
6	[Icon]	☹️	🔒	🔔	☒	10.0.0.21	RS2-FX/FX	Hirschmann	Rail 1		7.01
7	[Icon]	☹️	🔒	🔔	☒	10.0.0.22	RS2-TX/TX	Hirschmann	RS2 2		7.01
8	[Icon]	☹️	🔒	🔔	☒	10.0.0.23	RS2-TX/TX	Hirschmann	RS2 3		7.01
9	[Icon]	😊	🔒	🔔	☒	10.0.0.31	M-BASIC4		M1	RR, RM, Ch..	3.20
10	[Icon]	😊	🔒	🔔	☒	10.0.0.32	M-BASIC4		M2	Chassis300..	3.20
11	[Icon]	☹️	🔒	🔔	☒	10.0.0.33	M-BASIC4	M3	M3	RR, Chassi..	3.20
12	[Icon]	😊	🔒	🔔	☒	10.0.0.103					
13	[Icon]	☹️	—	🔔	☒	10.0.0.111					
14	[Icon]	😊	🔒	🔔	☒	10.0.0.112					
15	[Icon]	☹️	—	🔔	☒	10.0.0.250					
16	[Icon]	☹️	🔒	🔔	☒	10.0.0.254	RS2-TX/TX	Hirschmann	RS2 4		7.01
17	[Icon]	😊	🔒	🔔	☒	127.0.0.1					

Picture 7: Network Survey with HiVision

The drawback of a configuration via WEB interfaces consists in the fact that only one unit can be configured at a time. However, often one has to proceed at adjustments which are to be valid for a number of systems; for instance, you want to configure the trap receiver for SNMP messages network-wide or you want to implement VLANs over many switches. Here the network management Tool HiVision is particularly useful. If you use HiVision for configuration all adjustments can be effected

alike in the WEB Interface. The current status is presented in a clear way by means of a photo-realistic picture. Thus defective ports or errors committed by the agent can immediately be recognized from the colour.

If you configure several systems at a time you can just use those parameters which are available on all systems selected.

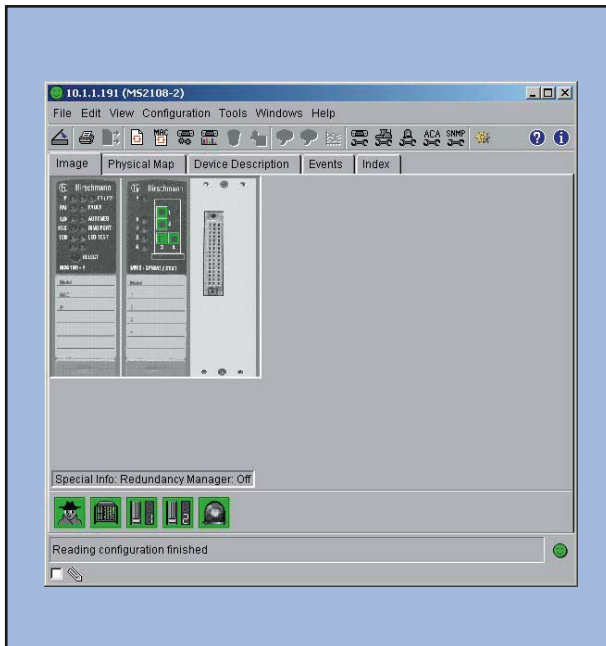

**Picture 8: Unit Presentation of HiVision**

Management of this tool can be learned within a short time provided, however, you are familiar with the units and network protocols used.

### **Unit Exchange with the Auto-Configuration Adapter (ACA)**

To facilitate the unit exchange so that staff members who normally do not work with networks will also be able to exchange switches Hirschmann has introduced the Auto-Configuration-Adapter. It is a “stick“ with flash memory which can be inserted into the V.24 console port.

The ACA functions as follows:

- There is an ACA for each switch as only one configuration can be stored per ACA.

- As soon as the configuration or re-configuration of a switch has been completed the ACA is plugged onto the switch and the configuration is stored locally. The switch is able to recognize by itself that an ACA was inserted and stores his configuration, both in the local configuration list and on the ACA.
- If a switch is exchanged the ACA is inserted into the new switch before the unit is turned on. Now the new switch recognizes the ACA and loads the configuration stored thereon. With industrial switches of the RAIL and MICE series, it might be required to adapt the position of the DIP switches of the exchanged unit as well.

It is a precondition for the application of a ACA that the new and the exchanged switch are identical. Furthermore, the software versions must be identical, too.

An advantage of this method consists in the fact that you can exchange a switch without having to access to the switch itself via the network. In case of a software update or a configuration modification the data are loaded into the ACA anew.

### **Modularity: Addition/Exchange in Operation**

When it comes to failure security, one also has to consider the question regarding the exchange of units and whether it is possible to exchange modules during operation.

A uniform answer cannot be given as this depends on the components selected.

Of course, the RAIL series cannot be exchanged without downtime of the switch concerned since this system is composed of firmly structured units.



This is different for the MICE systems: an individual module can be exchanged during operation without having to switch off the entire switch provided that the module is identical or that the module is operated as plug'n-play. Thus it is recommendable for the spare parts management to have at least one piece of all modules used in store.

In case of the MACH switches 3002 and 3005, it is possible to exchange the individual basis boards during operation but not the modules on the basic boards.

### **Help Functions**

Here it should be mentioned that the entire help system of Hirschmann as well as the documentation are of excellent quality. Both is available in English and German and both versions are up-to-date. With the exception of the text-based user interface via console or telnet, the online help is not only very detailed but supplies extensive information on the techniques applied. Handling is comfortable. In HiVision, there is the possibility (in the form usual for many Windows programmes) to call the help function by way of the menu bar. In the case of the WEB interface, the help function is located in the same mask where the adjustments can be effected, too. Furthermore, one has the possibility of activating the help function by means of the left menu bar.

The documentation goes beyond the pure help function: most of the chapters have a short introduction into the respective problem so that the reader will quickly become acquainted with the general subject and does not get the feeling to be left alone with just the pure help description. The documents have been subdivided according to subjects so that the reader easily finds what he is looking for.

### **Summary**

- Due to missing functionalities and relatively complicated implementation, the user interface is only recommendable for the commissioning of the Hirschmann switches.
- For a limited number of systems, the Browser Interface is sufficient.
- For medium and large-size networks, HiVision should be applied since it facilitates considerably both handling and monitoring.
- The use of ACAs is reasonable if you want to set up a network which also functions without the continuous presence of skilled personnel. Likewise, it is possible that, in case of maintenance work, standstill times can be reduced to a minimum which is an absolute must, especially in the industry. However, one should take into account that the network personnel should show the necessary discipline to keep the configuration stored on the ACAs always up-to-date.
- Both help function and documentation are a success: the theoretical knowledge required is in most cases introduced by way of a short comment and the explanations on configuration parameters are informative and easy to understand.

## Redundancy Process

### RSTP

It would go beyond the scope of this product report to describe the rapid spanning tree in detail. Instead, we recommend the lecture of the ComConsult Report by Petra Borowka and Markus Schaub („Design-Varianten Lokaler Netzwerke im Vergleich“, only in German) with examples of applications or the Insider article published by Markus Schaub in December 2002 („Der schnelle Baum“, only in German).

An essential characteristic of this process is the fact that it does no longer work on a time basis alike the classic spanning tree but by way of actions which are triggered on an event-controlled basis. If a line fails the Rapid Spanning Tree Process can immediately react to this failure and thus keep the failover time to a minimum. After rebuilding of a new, stable topology all switches of the tree are instructed to cancel the necessary entries of their bridge table.

Three peculiarities of the RSTP should be underlined as they could retard the end-to-end communication considerably:

1. A switch must recognize a link failure or a link activation by way of a link-up or link-down. If, for instance, a media converter is switched between two switches, which does not transfer the link status, it will take some time for the failure to be detected, i. e. until non-arrival of the BPDU has been reported.
2. Not all manufacturers are using event-triggered BPDU packets to circulate changes but use the ones regularly sent out. This, however, in the worst case, might take 12 seconds.

3. For the topology change messages often the regular BPDUs are sent so that here, too, it might take relatively long until all switches have received the information.

Furthermore, it should be noted that, with the rapid spanning tree, frames may be doubled or changes in the order of the frames transmitted from the sender to the receiver may be produced by a switch-over.

### Hirschmann Process

The core of the processes developed by Hirschmann is the HiPER Ring. The idea behind is that a complete network can be subdivided into rings which are interconnected with one another on a redundancy basis.

Picture 9 shows such a design of different interconnected ring networks: the backbone and the individual control levels are set up by means of the HiPER Ring; the rings themselves are either connected with one another by means of the new HiPER Ring coupling (brown lines in the picture) or the older process, i. e. Dual Homing (red lines in the picture).

Due to the combination of coupling processes and rings a typical topology will be created which connects a backbone ring to the control rings by a star-shaped structure. As both in each individual ring and in the redundant ring coupling one line is deactivated a loop-free topology is created.

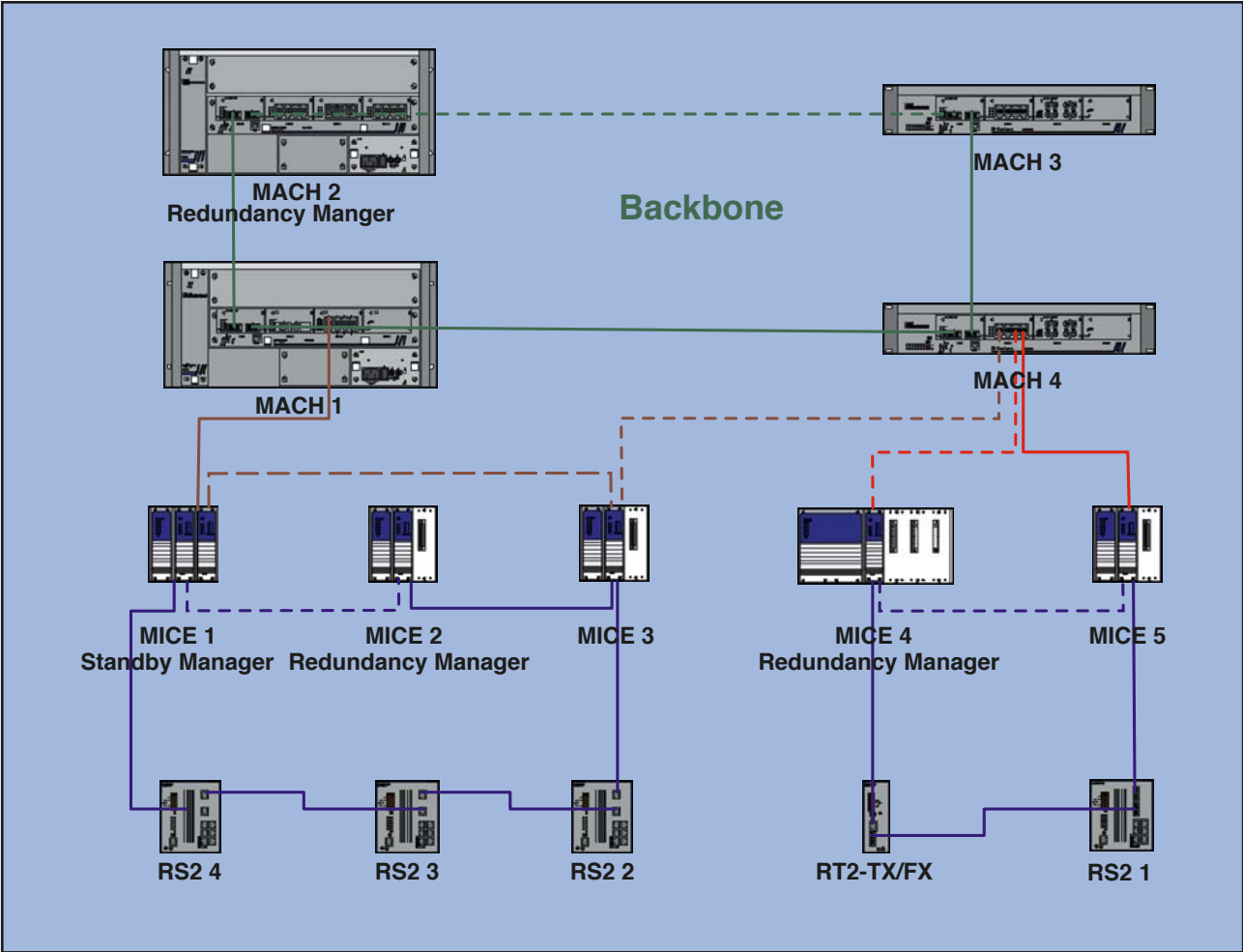

Picture 9: Design with Hirschmann Process

**HiPER-Ring**

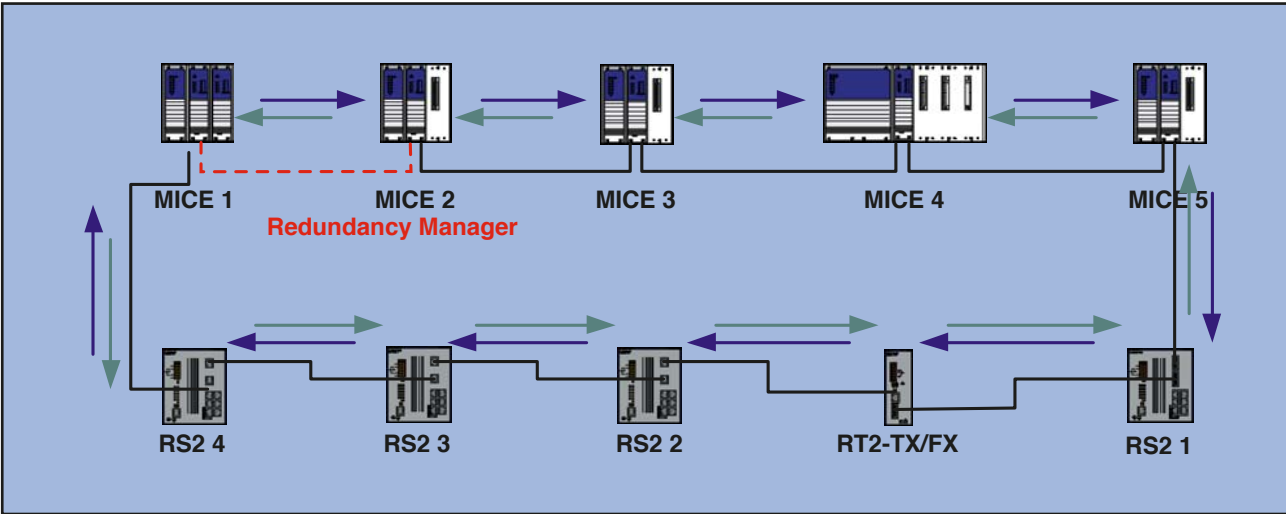

Picture 10: Monitoring of a HiPER Ring

In each ring, there is a station called redundancy manager. To avoid a loop the redundancy manager will interrupt the ring as follows: data frames received on a passive ring port, which belongs to the ring, will no more be processed nor will they be sent out from the port (red-dashed line in the picture; the port of MICE 2 in the direction of MICE 1 is the “passive ring port”).

For the monitoring of the ring, the redundancy

manager will send out, every 100 ms, so-called watchdog packets in both directions of the ring (see Picture 10), and, of course, also to the port which stopped processing incoming frames. If three watchdog packets in one of the two directions get lost the redundancy manager will recognize an interruption of the ring and activate the passive port. Thus again a completely connected topology will be generated despite failure of a line or a unit.

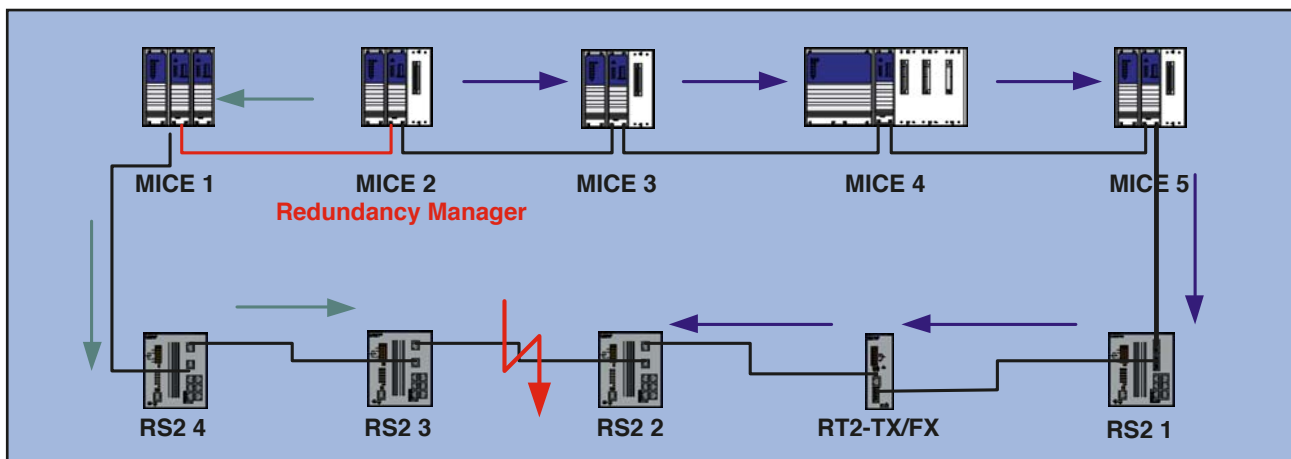

**Picture 11: Error removal in the HiPER Ring**

Following activation of the blocked port by the redundancy manager the latter will go on sending watchdog packets so as to recognize the rebuilding of the starting topology as well. If, as shown in the example, the defective line between RS2 2 and RS2 3 is replaced the watchdog packets will again be able to pass the line and the redundancy manager will then deactivate the port leading to the system MICE 1. To avoid the creation of short-term loops in the ring, the systems will discard the data frames in the memory until the ring has been rebuilt.

In contrast to the spanning tree, the failover time of the HiPER Ring does not depend on the number of systems used. The retarding factors additionally caused by a great number of switches are the transit time of the

watch-dog packets on the cables, the delays per switch due to the system and one packet maximum which a switch has just begun to send out as a watchdog packet comes in. However, these factors have just a minor influence on the failover time, as will become evident in the measurement tests as well so that even in the case of 50 switches and a line length of 3.000 km a failover of less than 500 ms can be guaranteed.

According to the indications given by the manufacturer, it is not possible that a frame will be doubled or the frame order will get mixed up as a consequence of the failure or the rebuilding of a ring as can happen with the RSTP process. This statement is also applicable for all other redundancy processes of Hirschmann.

## Dual Homing

Originally, a HiPER Ring consisting of hub systems was connected to the backbone by means of Dual Homing. To do so, two units of the ring are connected to a unit, a modular switch of the MACH series (see Picture 12).

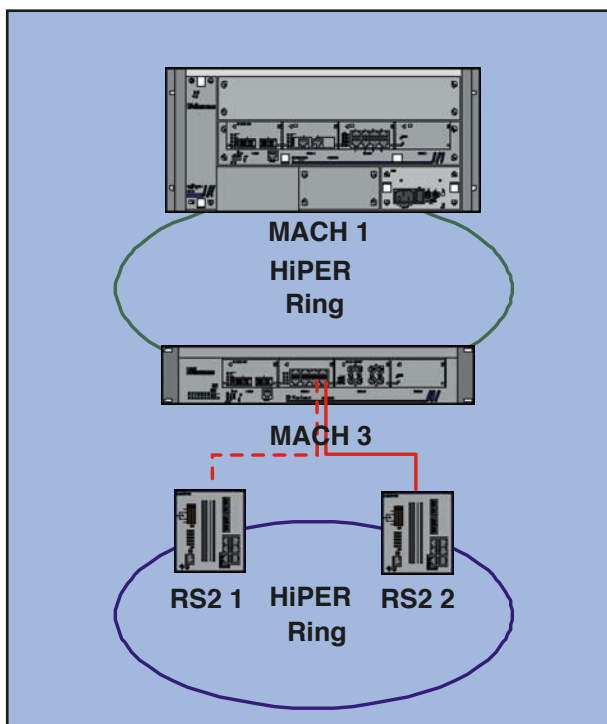

**Picture 12: Dual Homing**

The Dual Homing is configured on the MACH 3 which switched one of the two ports into the discarding mode. If the primary connection fails the MACH can put the secondary connection almost immediately into operation.

An advantage of the Dual Homings is the very short failover time. A serious disadvantage, however, is the fact that the backbone switch is a single-point-of-failure. To compensate this drawback, it is possible that Dual Homing ports use different basis boards of the same MACH unit. However, with this process there is still the risk of a failure of the entire modular system – a default which cannot be compensated.

Another drawback is the fact Dual Homing is not suitable for the coupling of two control rings with one another since the function is only available for the MACH series.

## HiPER Ring coupling

The more modern HiPER Ring coupling does no longer have these disadvantages. In this process, redundancy is provided by means of the switches in the control area. For this purpose, a switch is configured as standby manager. Subsequently, the latter and another switch of the ring are connected to one or two different units of another ring. Furthermore, the two are connected with each other via a special “standby port“. One of the two switches is now the master which activates the coupling line to the other ring; the other switch, which has become the slave, sets his port into the discarding mode.

If the connection of the masters to the other ring is interrupted it will immediately inform the slave and the latter will activate his connection.

Since, theoretically, the connection of the other ring can be interrupted as well – in this example between MACH 1 and MACH 3 – or the standby line between RS2 1 and RS2 2 can break down master and slave will exchange test packets as in case of the HiPER Ring. If these test packets do no longer arrive RS2 2 will also activate his connection to MACH 3, independently of the fact that the order regarding the control line in default has not been received; however, this kind of failover is significantly slower, as shown by the test.

Approx. by the end of 2003, a solution for the MICE switches will be available where the additional control line can be dropped by replacing it with control packets.

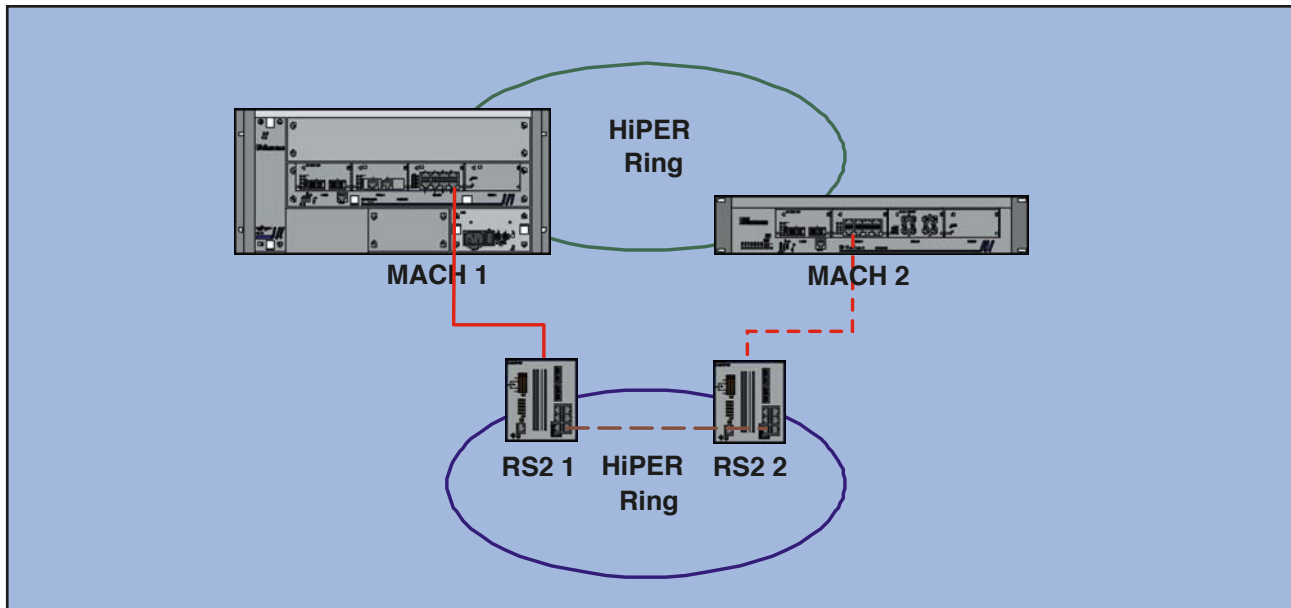

**Picture 13: HiPER Ring coupling**

## HiRRP

The Hirschmann Router Redundancy Protocol, shortly HiRRP, is a typical router redundancy process alike VRRP. The basic functioning of these protocols will not be explained in detail here; as literature, we recommend the article published by Petra Borowka in the Network Special Insider (“Protokolle zur fehlertoleranten Konfiguration des Default Router Eintrags”, only in German) or the more detailed ComConsult Report with application examples (“Design-Varianten Lokaler Netzwerke im Vergleich”, only in German) by Petra Borowka and Makus Schaub.

A special characteristic of the HiRRP process is the fact that, compared to the standard protocol VRRP, it has a distinctly shorter failover time of less than 800 ms instead of 3 to 4 seconds with VRRP. Furthermore, configuration has considerably been facilitated. However, each time only two routers can use one virtual IP address, not, as with VRRP, as many as required which, however, suffices in most cases.



## Test of the Redundancy Processes

### Test Processes Applied

As it is difficult to determine the “real” failover time we opted for an indirect measurement procedure which is also more relevant in practice: the time period is measured during which a client system does not receive packets. For this purpose, a continuous data flow is initiated between two PCs on UDP/RTP basis by means of a load generator, i. e. Chariot by Ganymede.

Each test period lasted 10 seconds during which the ring was interrupted and rebuilt once. During these 10 seconds, 2000 packets with 1000 bytes each were sent, which corresponds to a frequency of 0.5 ms as time distance between two packets.

At the end, the duration of the connection interruptions was calculated on the basis of the loss rate of bytes.

### HiPER Ring

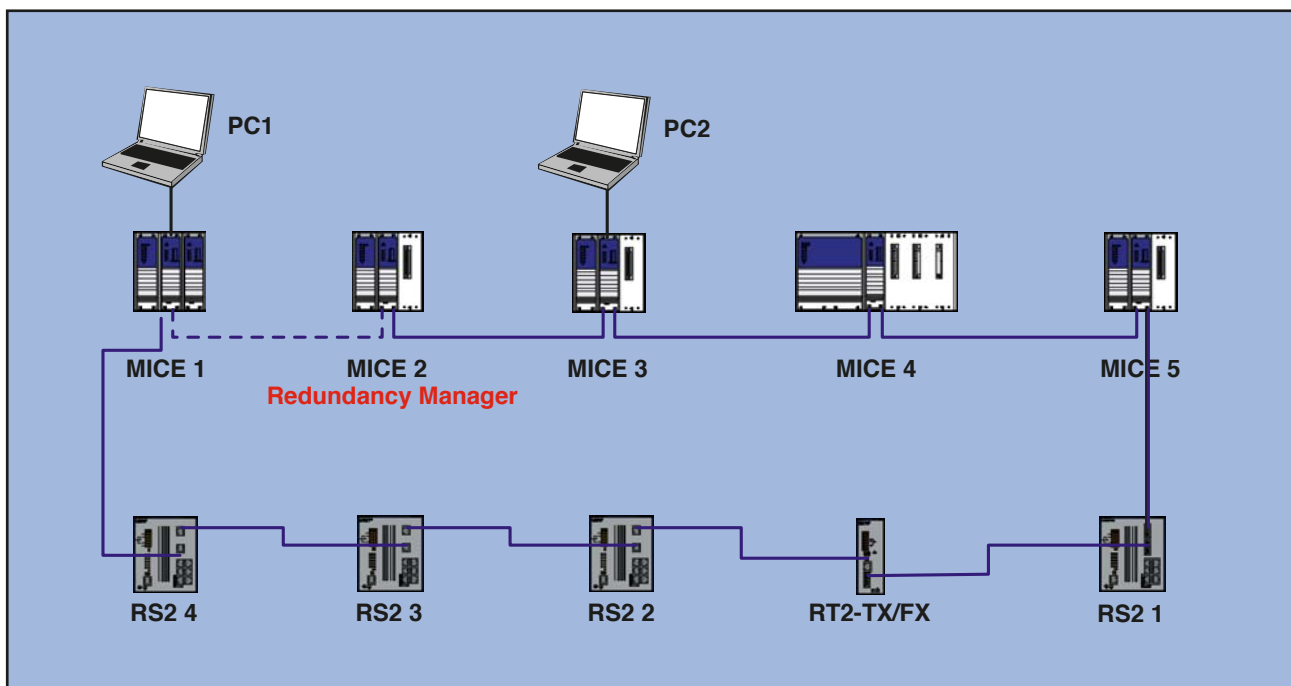

**Picture 14: Test Sequence of the Fast-Ethernet HiPER Ring**

In the tests, five MICE systems and four RAIL switches were used. The MICE-MICE coupling was entirely put into practice with glass fiber, for the connection to the RAIL systems one time twisted-pair (MICE 1 to RS2 4) was used and one time glass fiber (MICE 5 to RS2 1).

In all tests, MICE 2 was the redundancy manager and the ring port to MICE 1 was the passive port in the default-free ring.

The two test units were connected to MICE 1 and MICE 3 so that in the thus generated ring the packets were forced to run through all switches; this way the packet loss was maximised since each time the line had the maximum extension.

### Failure of Different Connection Types in a Fast-Ethernet HiPER Ring

At first, the reaction time to the failure of lines for a HiPER Ring with nine industrial switches was tested. Here it was verified what impact the various failure possibilities have on the recovery time. The results are shown in Result 1.

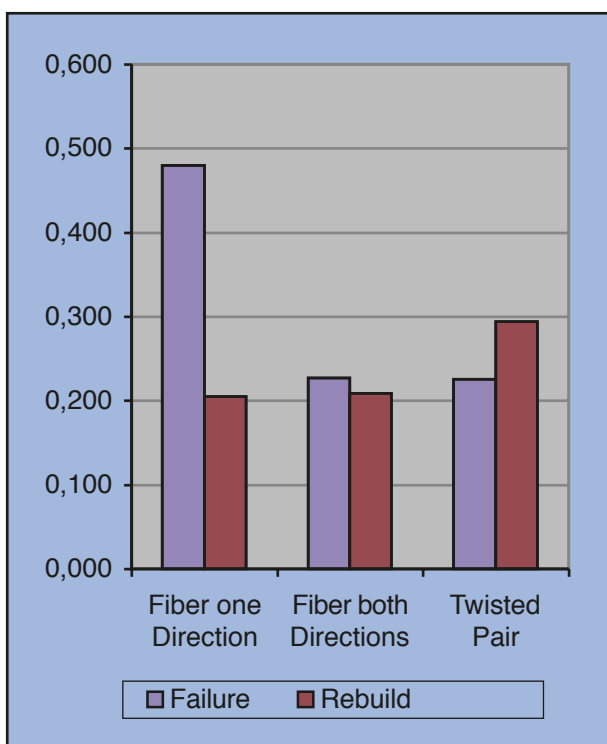

#### Result 1: Reaction to different line failures

At first, it is striking that there is a considerable difference whether one or both directions of a glass fiber connection are down. While it is possible to repair the failure of both directions within approx. 200 ms, the HiPER Ring needs more than twice the time for the repair of a failure of only one glass fiber direction and nearly reaches the deadline of 500 ms indicated by Hirschmann as maximum down time.

The reason of this significantly varying reaction is the fact that the link failure is immediately recognized as link-down by one of the units only and then sent to the ring manager. If, in an unfavorable case, the ring manager receives this message on the passive port, it will not interpret the packet and thus switch-over is not exercised by event-control but is recognized by the ring manager due to the missing watchdog packets and remedied accordingly. This reaction of the ring manager is identical both for the MICE and the RAIL switches. A MACH system as ring manager would, according to Hirschmann, also process the signal packet on a passive port.

Since in case of a failure of the twisted pair cable both directions are down this failure is also remedied by event-control; the same goes for a simultaneous failure in both directions of an optical fiber cable.

After rebuilding of the ring, the reaction will also occur event-controlled. The problem of "one-sided" error messages does not arise this time. The down-time of the failover is approx. 200 ms for glass fiber, for twisted-pair it is approx. 300 ms as the auto-negotiation process takes longer and additionally retards the switch-over process.

#### Failure under Load

The structure of the previous test remained unchanged. This time, however, in addition to the data flow of the test process a basic load of 40 Mbit/s was generated between the two test stations so that the ring was exposed to a throughput of approx. 56 Mbit/s while only one direction of an optical fiber connection was interrupted.



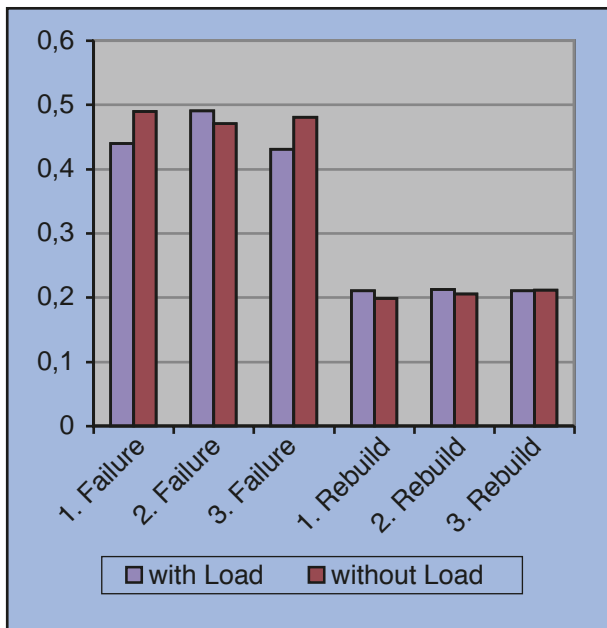

### Result 2: Switch-over with ring load

In Result 2, the results of an unloaded ring are compared to those of a ring with load. One can see very clearly that, in the three measurements taken, there are no significant differences between the loaded and the unloaded ring.

As no difference had been measured in the tests run with or without load all further tests were effected without load.

### Test Flow in Both Directions

The next test with unchanged test sequence was designed to check whether the direction of transmission is of importance.

For this test, a data flow was simultaneously transmitted from PC 1 to PC 2 and from PC 2 to PC 1. In Result 3, the results of three tests for each direction are compared to a measurement in only one direction for the rebuilding of the ring. As expected, the result demonstrates that there is no difference as to the direction the data flow or whether the analysis is made one or both directions.

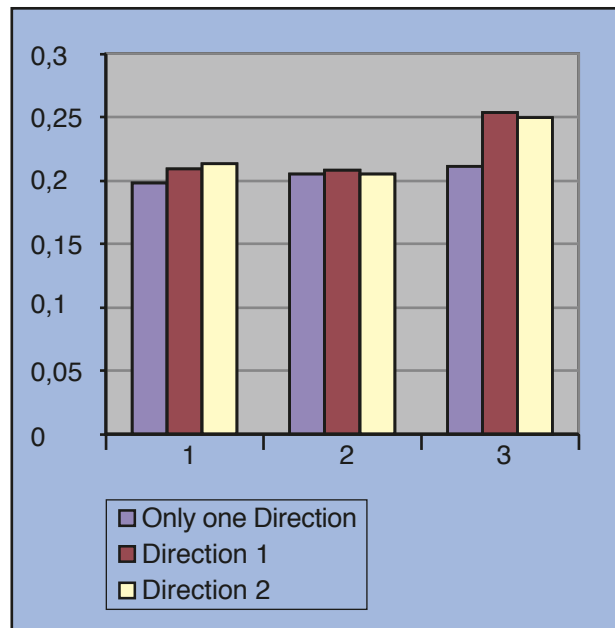

### Result 3: Impact of the measurement direction

For reasons of simplification, only one data flow in one direction was used for the measurements in the following tests.

### Influence of the Number of Switches in the HiPER Ring

In their leaflets Hirschmann indicate that the extension of the ring and the number of switches hardly have any repercussion on the failover time. For this reason, the number of switches was increased from three to nine in the following test. At first, the MICE switches were used in an increasing number, and subsequently the RAIL switches were implemented as well until the ring sequence of the previous tests was achieved again. For each measurement, the one of the two glass fiber connections most distant from the ring manager was disconnected so as to measure the delay of the greatest number of switches possible during transmission of the event messages.

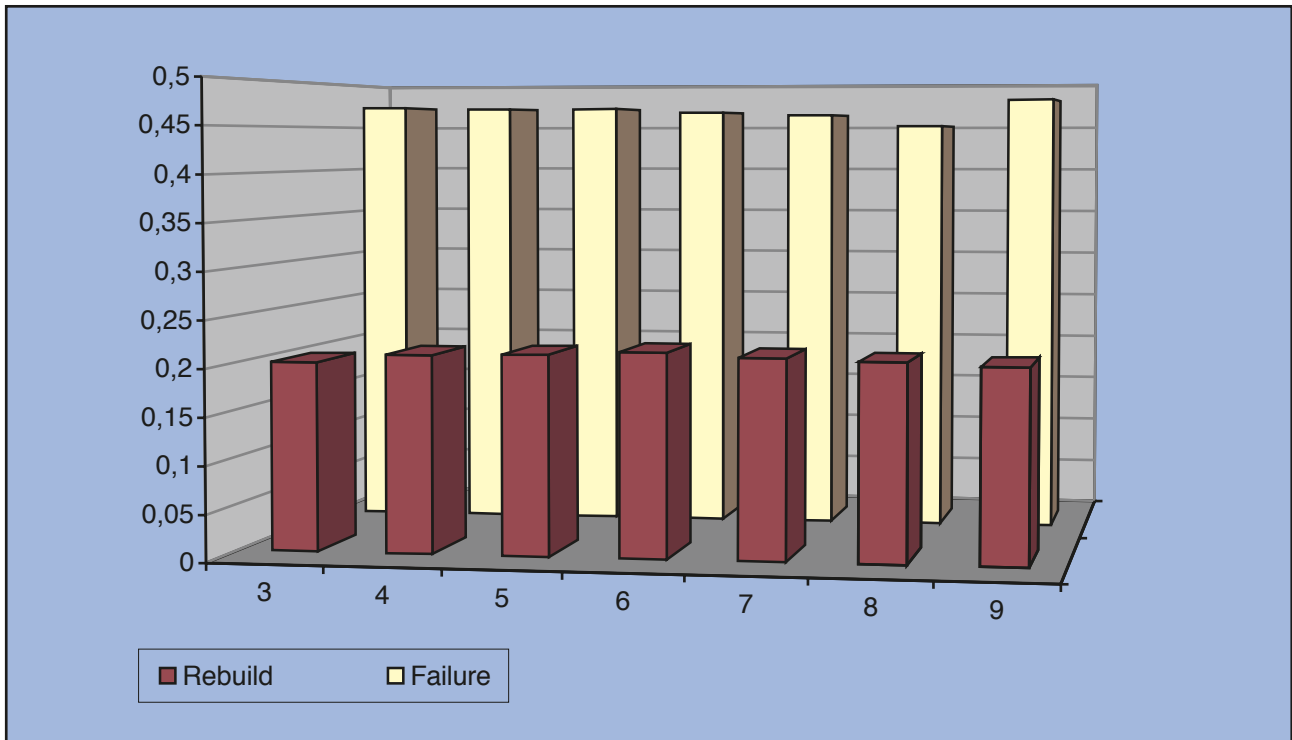

**Result 4: Number of the switches in the HiPER Ring**

From the result diagram, you can see four aspects very clearly:

1. The number of switches has no influences on the failover time of a HiPER Ring. The variations during the recovery of a line interruption are within the scope of deviation to be expected.
2. The switch series does not seem to have any impact on the failover time either.

3. The mixture of optical fiber and copper connections necessary from the seventh switch onward due to the test units used does not make any difference either.
4. The failover time was always below 500 ms.

### Gigabit HiPER Ring

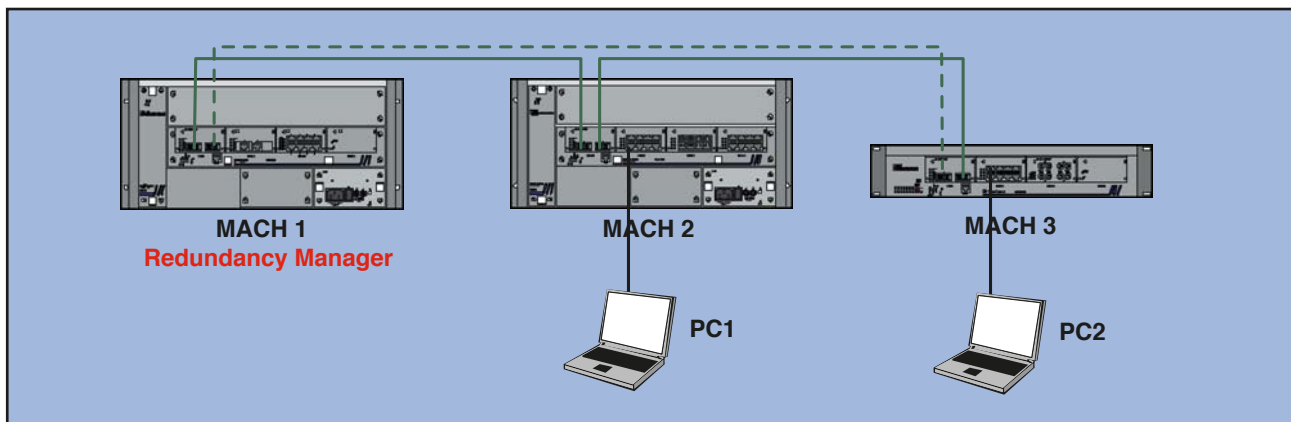

**Picture 15: Test structure of Gigabit Ethernet HiPER Ring**

In the tests, two MACH 3002 and one MACH 3001 were used. The MACH switches were interconnected to the glass fiber basis by means of a Gigabit HiPER Ring. During the tests, the cable between MACH 2 and MACH 3, which was not connected to the ring manager, MACH 1, was interrupted.

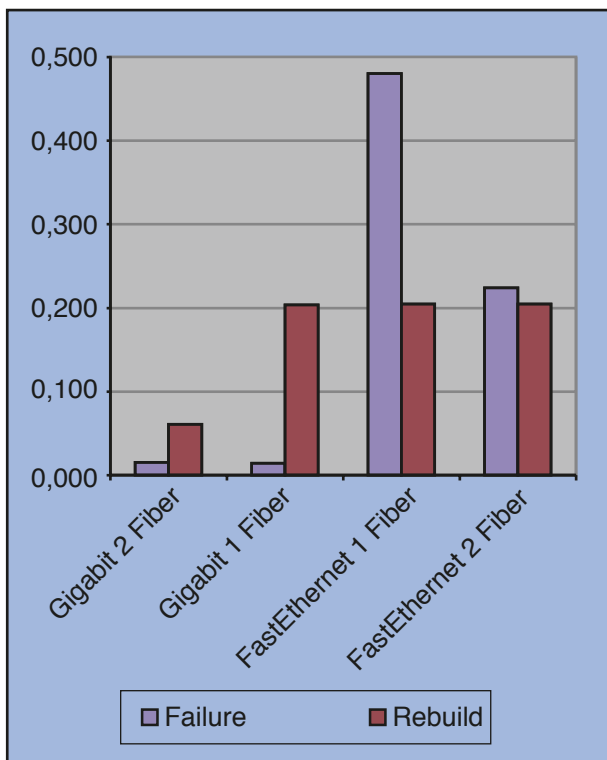

**Result 5: Comparison of Fast-Ethernet vs. Gigabit-Ethernet HiPER Ring**

In the diagram, the results of the interruption of one and both glass fiber connections are compared. The results reveal the following aspects:

- In case of a failure of the ring, the Gigabit HiPER Ring is significantly faster than Fast-Ethernet ring. The two reasons are the faster reaction of the MACH systems with processors of higher performance capacities and the ten times higher transmission speed of error messages with Gigabit.
- It is without importance for the failover time whether one or both fibers of an op-tical waveguide connection are down. Thus the statement is confirmed saying that a MACH switch can also process event-controlled packets on a passive port.
- In contrast to the Fast Ethernet, on rebuilding the Gigabit ring switches more slowly than in case of a failure. According to Hirschmann, the reason for this is the delay caused by the auto-negotiation process.
- The asymmetric delay caused by the auto-negotiation process can be measured only if an optical fiber cable is disconnected.

**Ring coupling**

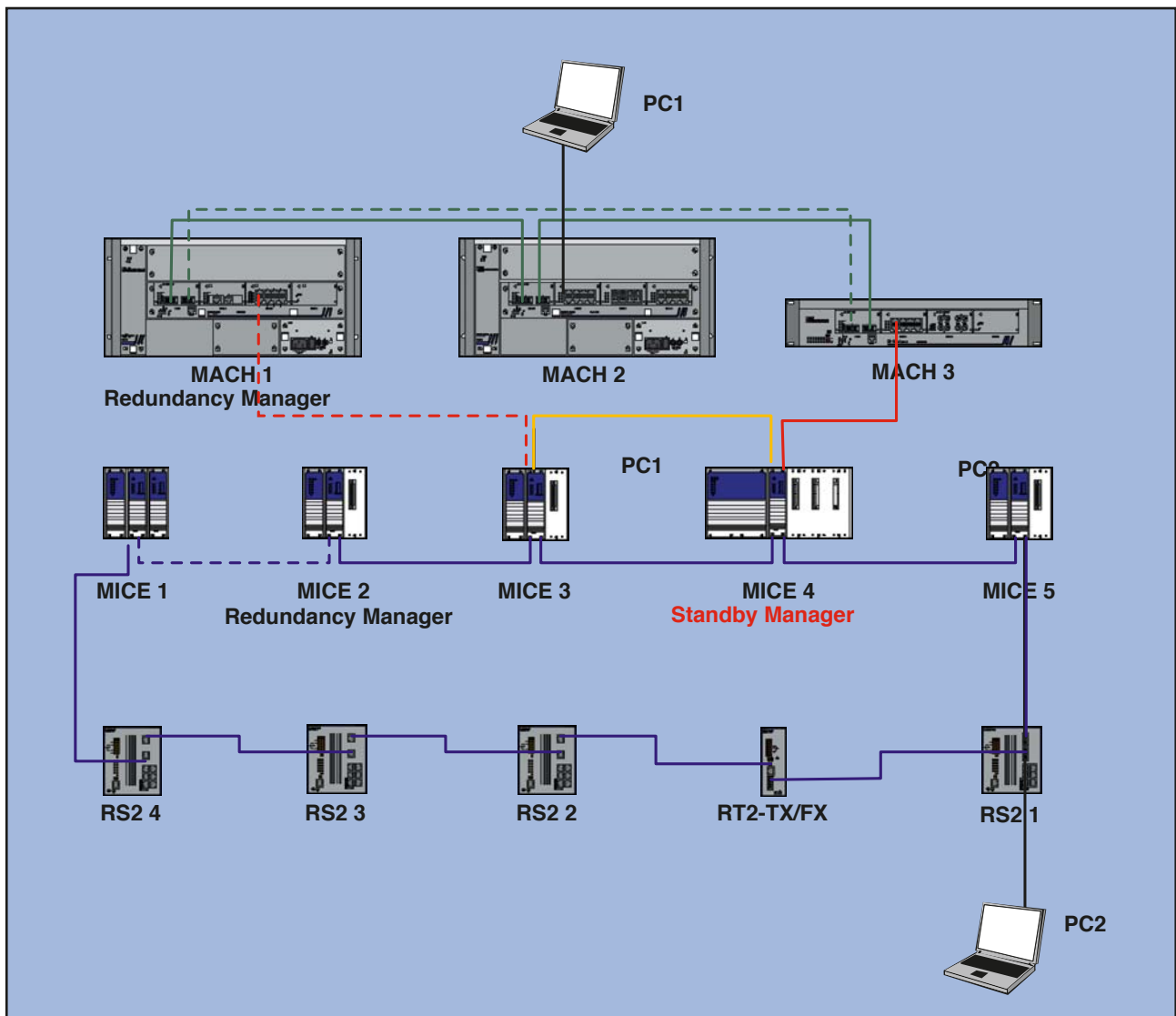

**Picture 16: Test structure of the HiPER Ring coupling**

For the switch-over test of the HiPER Ring coupling, the Fast-Ethernet HiPER Ring and the Gigabit-Ethernet HiPER Ring were connected with each other. The structure is shown in Picture 16; the orange line is the control line between the standby manager and the standby partner.

For the test, the switches were configured in a way to ensure that they return to their status after rebuilding of the original

connection. Subsequently, the failover times of failure and rebuilding of the line between MICE 4 and MACH 3 were measured. In a second test, the down time was measured resulting when the control line is also defective or not connected (Result 6).

If the control line is connected the failover times are approx. 200 ms; this is valid for the failure as well as for the rebuilding of the ring.

If the control line is missing down time will be increased by a multiple to over 1.4 seconds which is by far in excess of the tolerance value of 500 ms defined by Hirschmann. However, this case would only occur if the control line was defective. Thus, following commissioning of a HiPER Ring coupling the control line should be examined carefully by the management as to correct functioning and should also be monitored during operation.

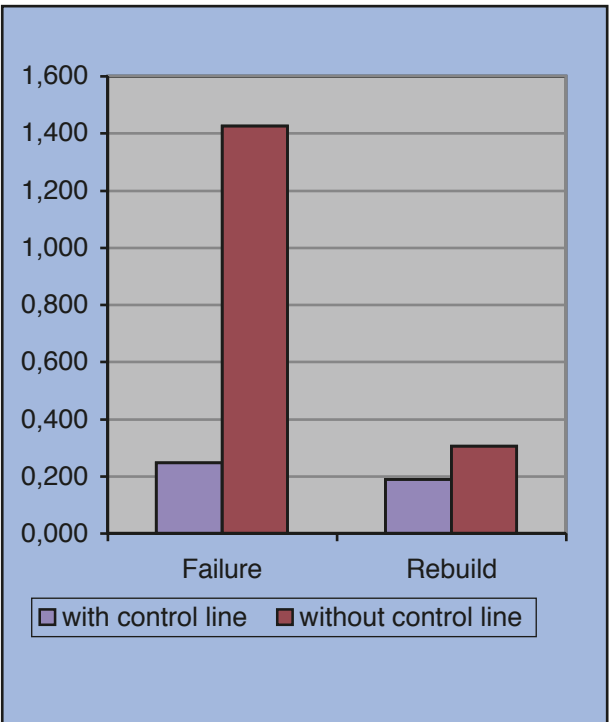

**Result 6: Failover times of the HiPER Ring coupling**

**Dual Homing**

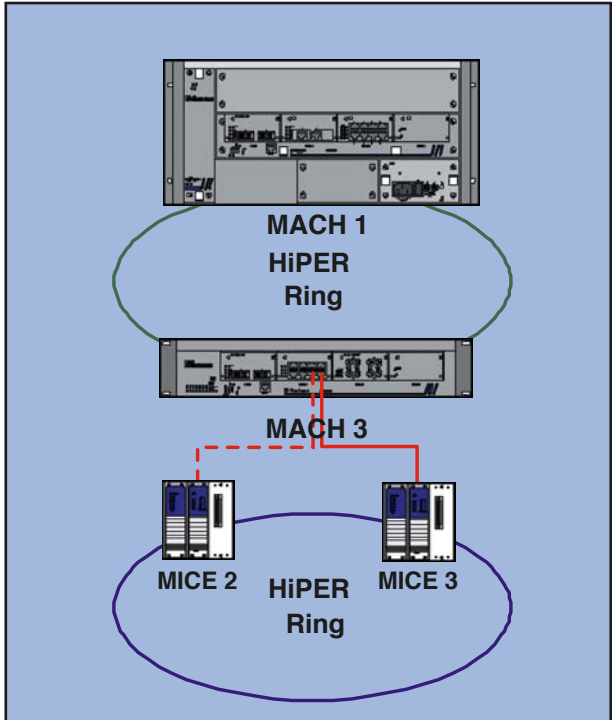

**Picture 17: Test structure Dual Homing**

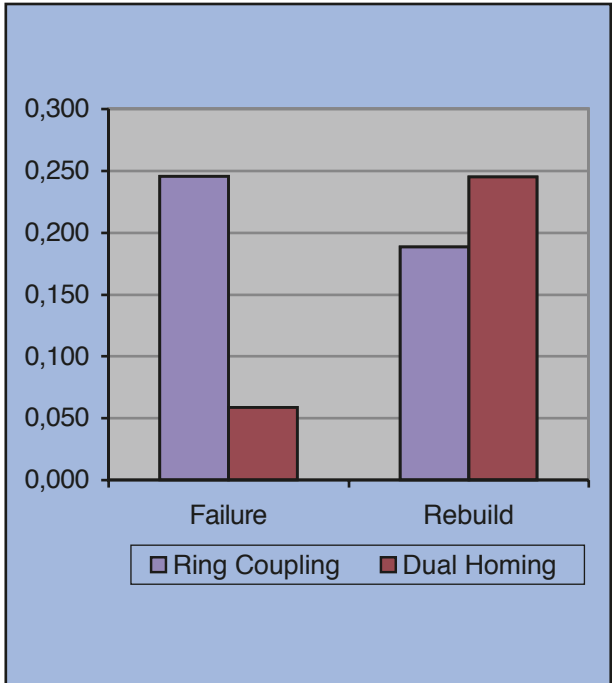

**Result 7: Dual Homing vs. Ring Coupling**

For the Dual Homing test the test sequence remained nearly unchanged, only the ring coupling was turned off and Dual Homing was configured at the MACH 3 which was connected with the two RAIL switches MICE 2 and MICE 3.

Also in the Dual Homing process, failover times will remain below the 500-ms limit value. In case of a failure of the primary line switch-over will be effected within approx. 50

ms. Rebuilding will be exercised within a time range of 250 ms.

If you compare Dual Homing with the modern ring coupling, it is striking that switch-over is much faster in case of a failure at the older process than for the more modern one method. Background for this better switch-over reaction is the fact that the failure is determined and corrected by means of a unit.

**HiRRP**

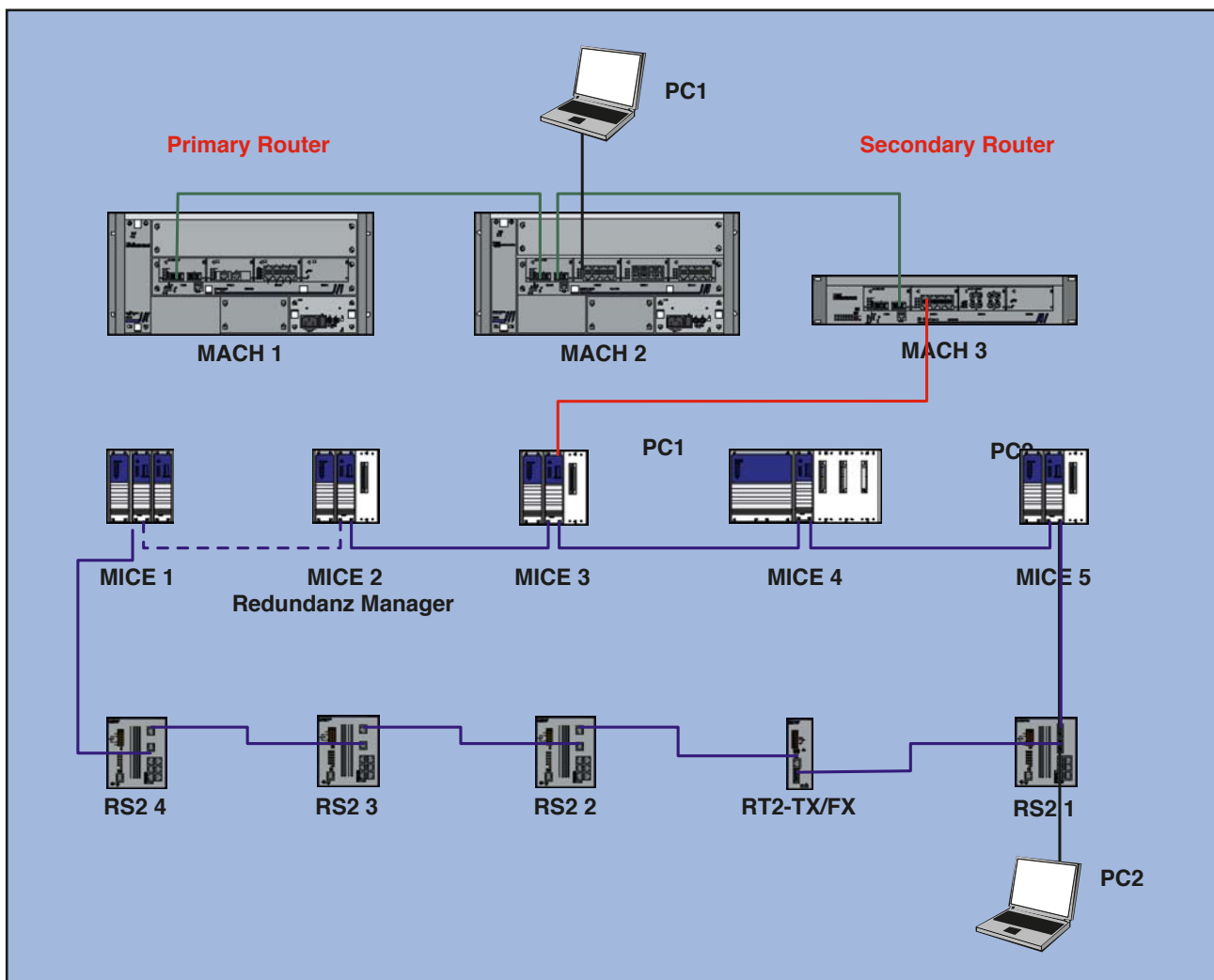

**Picture 18: Test structure of HiRRP**

To be able to measure the HiRRP process without influences by other factors the

Gigabit HiPER Ring of the MACH switches was replaced by a linear sequence.

The two router modules of MACH 1 and MACH 3 were configured for HiRRP. MACH 1 was an active router for both test stations as long as both could be reached. In this test, the failure of the connection between MACH 1 and MACH 2 was tested which caused that MACH 1 could no longer be reached.

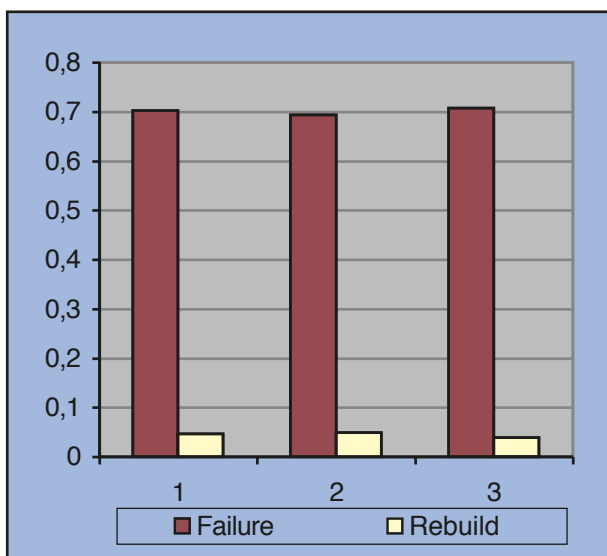

**Result 8: HiRRP**

For the failure of the active router, a failover time of approx. 700 ms was measured. This time is within the range expected of below 800 ms which was calculated on the basis of theoretical facts. The switch-over is significantly higher than that of the HiPER Ring so as to ensure that first a Layer-2 recovery can be effected prior to changing something in Layer 3. If, for instance, the original Gigabit HiPER Ring were still active in the test sequence the line failure could have been compensated by a switch-over to the redundant connection and thus a switch-over of the Default Gateway function would have been unnecessary.

A comparison: if you operate VRRP with the default values a failover time of 3 to 4 seconds is measured, with HSRP even around 10 seconds.

**HiPER Ring vs. RSTP**

In the next tests, the RSTP process was tested and the results were compared with the HiPER Ring.

**Test Sequence of RSTP**

For the tests of the Rapid Spanning Trees, each time four 2950 workgroup switches and four 2955 industrial switches of Cisco were used. Alike in the test of the Fast-Ethernet HiPER Ring, the catalysts were set up as ring. For the test, just the root was determined, the other default values of the RSTP remained unchanged. Each time, the time range was measured during which the exchange of packets between sender and receiver was stopped. In analogy to the HiPER Ring tests, the times for interruption as well as for rebuilding of the ring were measured. During all tests, sender and receiver were connected to the root and to a neighbour switch. To trigger the switch-over, this connection was interrupted.

**Failover time Reaction of RSTP over Eight Switches**

First the down-time resulting from a ring with eight switches was measured. In all, the test was repeated ten times. The results are shown in the below Result 9.

In comparison to the HiPER Ring, there are three striking differences:

1. The RSTP process requires considerably less time for the rebuilding of the original topology than for recovery in case of a failure. The reason is that for the rebuilding of the end-to-end communication “only” the link between the root and its neighbour had to be rebuilt and that there were no packets in the memory of the switch which had to be cancelled.

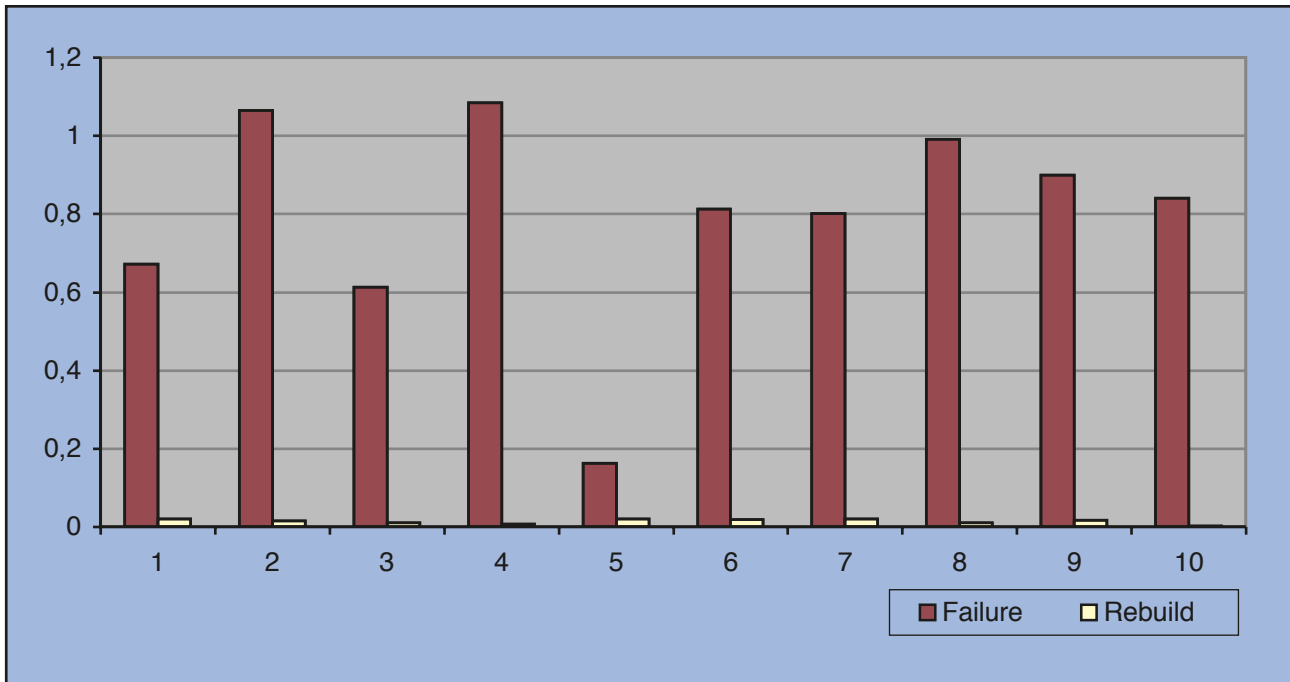

### Result 9: Failure and Rebuilding of a ring with RSTP components

However, this may cause a mix-up of the packet order at the receiver's end.

- The time required for recovery is subject to great variations and ranges between sharply under 200 ms and over one second for eight switches. In contrast to the HiPER Ring, the duration of failure cannot be characterized as deterministic criterion. In some cases, during rebuilding even more than two seconds were measured.
- The recovery time of an average of almost 800 ms is considerably higher than for the HiPER Ring.

### Worst-Case Failure with RSTP

The measurements taken in the previous test do not reflect the absolute worst case of the rapid spanning tree since the link-down of two switches is immediately detected and reported. However, it might happen that

media transducers are inserted in the ring or that systems are connected which cannot transmit a link-down to the switches and which themselves are not RSTP units. In this case, the failure must be detected by the absence of the BPDU packets. To simulate such a default situation, two units were inserted into the ring which do not speak RSTP but which are able to transmit BPDUs. Subsequently, the cable between these two components was disconnected.

Result 10 compares the failure which can be detected directly by the switches with the link-down which is only detected by the missing BPDUs. It is striking that the time increases by approx. the factor five and that the interruption is above 5 seconds.

Thus the time range is considerably better than the classical spanning tree but still ten times higher than the highest possible down time of the HiPER Ring.



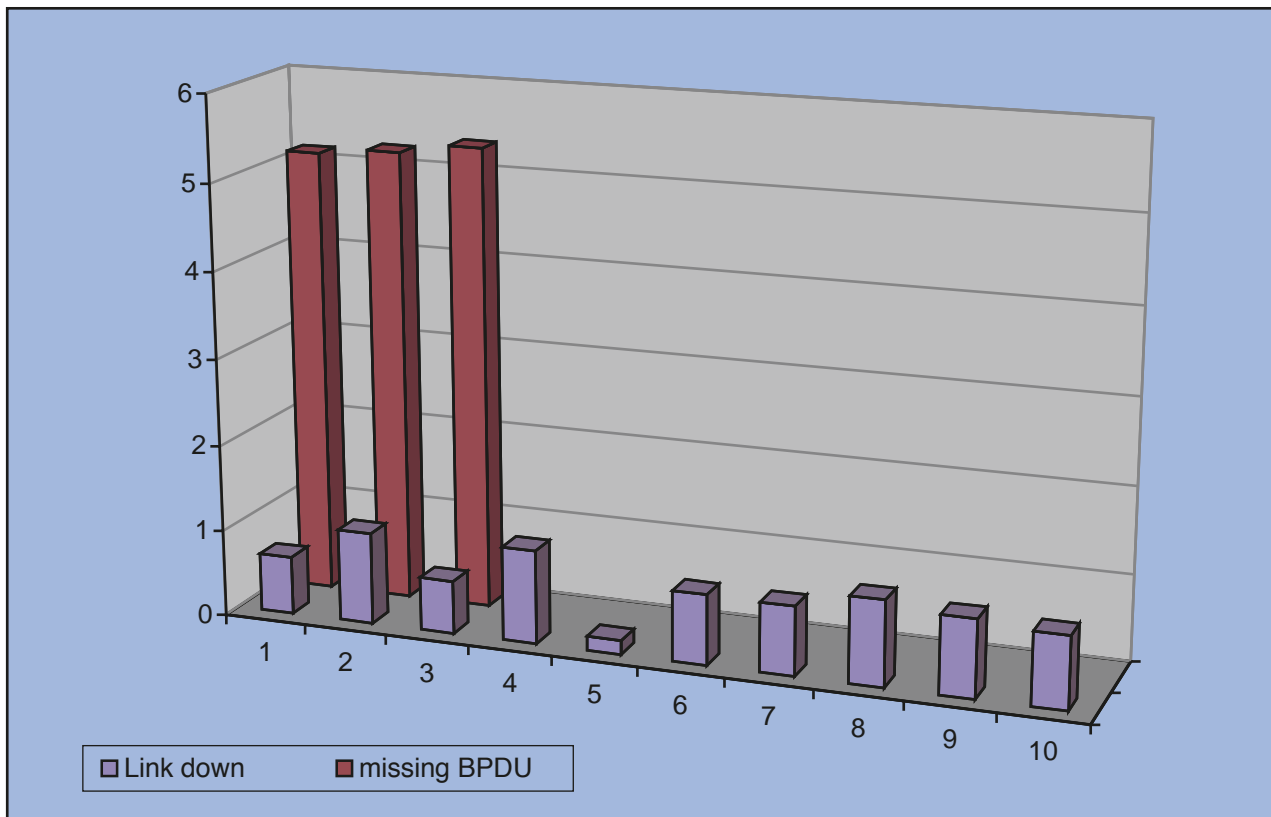

**Result 10: Link-down and missing BPDUs with RSTP**

**Increase of the Failover Time in Relation to the number of Switches**

In the last test with the RSTP components, the number of switches was step by step reduced from eight to three. Each time, three measurements were effected.

In Result 11 the results are compared to those of the HiPER Ring. The following can be seen from the diagram:

- The failover time of the RSTP process depends on the number of switches.

- For the HiPER Ring process, however, the number of systems is of no importance.
- Even if at first the failover time of the RSTP implementation is faster for up to four switches as compared to that of the HiPER Ring, it is subsequently rising strongly and is finally significantly higher.

In the drawing, it is astounding to see that four switches seem to switch faster than three switches and six faster than five. This is, however, due to the significantly varying failover times of RSTP which statistically have a major influence in the three measurements.

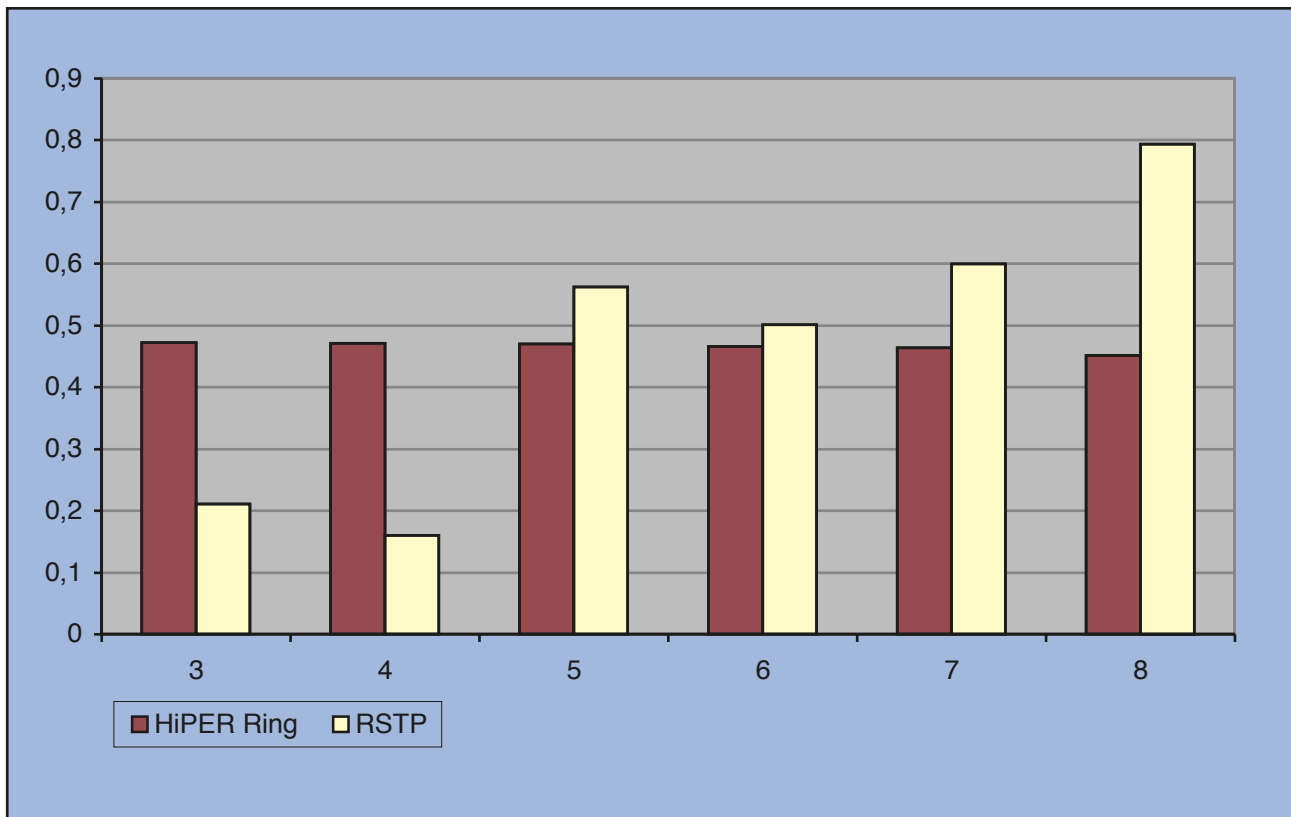

**Result 11: Comparison HiPER Ring vs. RSTP with differing numbers of switches**

**Important Remark on the Different RSTP Implementations**

The underlying implementation of RSTP in the Cisco switches does not represent that of all other manufacturers. As shown at the Sommerschule 2003 of the ComConsult Akademie, there are versions of the rapid spanning tree which cannot send event-controlled BPDUs but which make use of the

regularly passing packets (i. e. every 2 seconds) to disseminate modification messages. Here, with eight switches, propagation of an information will take up to 14 seconds.

Recommendation: If you want to implement RSTP in a failure-critical surrounding you should in any case run your own test to measure the failover time!

## Summary and Discussion of the Results

- Even in the worst case, all Hirschmann proprietary processes remain below the limit value of 500 ms regarding the failover times both in failures and in rebuilding processes following removal of the error.
- The only exception is the Router Redundancy Protocol HiRRP with 700 to 800 ms. However, as this is a Layer-3 process, for logical reasons, the time required here must exceed that of the Layer-2 mechanisms being located underneath.
- In the lab test of the ComConsult Lab, the statement made by Hirschmann was confirmed saying that the failover times are almost independent of the number of units forming a HiPER Ring.
- The rapid spanning tree achieves low failover times, too. In contrast to the Hirschmann process, however, they are subject to great variations.
- The failover times with RSTP are increasing significantly with the number of systems used and already exceed those of the HiPER-Ring with approx. four to five switches.
- If failover times are needed which, on the one side, are deterministic and, on the other side, are far below one second this cannot be achieved at present without taking recourse to proprietary processes like the HiPER Ring.
- Furthermore, the HiPER Ring is well suitable for projects with a large extension, i. e. where long lines and many switches connected in a row are required.
- In contrast to the HiPER Ring, with the rapid spanning tree packet repetitions and a mix-up of the packet order may occur during a link-down and a link-up.
- Advantages of the rapid spanning tree as against the Hirschmann process are that the rapid spanning tree is standardised and that only one technique is required to set up a flat Layer-2 network.
- When comparing the design, the following can be said: the guidelines laid down by the Hirschmann process are strict and not everything is possible; the rapid spanning tree allows more freedom, however, thus enhances the potential risk that an active topology will be generated which can hardly be understood, even less in case of an error.

## Pictures

Picture 1: Increase of the failover time in relation with number of switches	2
Picture 2: RAIL Switch	3
Picture 3: MICE Switches	3
Picture 4: MACH 3002	4
Picture 5: Configuration via hyper-terminal	9
Picture 6: Access via WEB Interface	10
Picture 7: Network Survey with HiVision	11
Picture 8: Unit Presentation of HiVision	12
Picture 9: Design with Hirschmann Process	15
Picture 10: Monitoring of a HiPER Ring	15
Picture 11: Error removal in the HiPER Ring	16
Picture 12: Dual Homing	17
Picture 13: HiPER Ring coupling	18
Picture 14: Test Sequence of the Fast-Ethernet HiPER Ring	19
Picture 15: Test structure of Gigabit Ethernet HiPER Ring	23
Picture 16: Test structure of the HiPER Ring coupling	24
Picture 17: Test structure Dual Homing	25
Picture 18: Test structure of HiRRP	26

## Results

Result 1: Reaction to different line failures	20
Result 2: Switch-over with ring load	21
Result 3: Impact of the measurement direction	21
Result 4: Number of the switches in the HiPER Ring	22
Result 5: Comparison of Fast-Ethernet vs. Gigabit-Ethernet HiPER Ring	23
Result 6: Failover times of the HiPER Ring coupling	25
Result 7: Dual Homing vs. Ring Coupling	25
Result 8: HiRRP	27
Result 9: Failure and Rebuilding of a ring with RSTP components	28
Result 10: Link-down and missing BPDUs with RSTP	29
Result 11: Comparison HiPER Ring vs. RSTP with differing numbers of switches	30

**ComConsult**  
**Technologie**  
**Information** 

**Pascalstraße 25 • 52076 Aachen**  
**phone 02408/955-400 • fax 955-399**  
**report@comconsult-research.com**  
**www.comconsult-research.com**